Ross Video Limited

DFR-8310(-C)

Multi-Definition Digital Products Frame and
Power Supply (PS-8300)

User Manual



Live Production Technology™

Ross Part Number: 8310DR-004

Issue: 02C



DFR-8310 • MD Digital Products Frame and Power Supply (PS-8300) User Manual

- Ross Part Number: **8310DR-004**
- Document Issue: **02C**
- Printed in Canada.

The information contained in this User Manual is subject to change without notice or obligation.

Copyright



© 2008 Ross Video Limited. All rights reserved.

Contents of this publication may not be reproduced in any form without the written permission of Ross Video Limited. Reproduction or reverse engineering of copyrighted software is prohibited.

Notice

The material in this manual is furnished for informational use only. It is subject to change without notice and should not be construed as a commitment by Ross Video Limited. Ross Video Limited assumes no responsibility or liability for errors or inaccuracies that may appear in this manual.

Trademarks

-  is a registered trademark of Ross Video Limited.
-  is a registered trademark of Ross Video Limited.
- Ross, ROSS, ROSS® are registered trademarks of Ross Video Limited.
- DashBoard Control System™ is a trademark of Ross Video Limited.
- All other product names and any registered and unregistered trademarks mentioned in this manual are used for identification purposes only and remain the exclusive property of their respective owners.

Important Regulatory and Safety Notices

Before using this product and any associated equipment, refer to the “Important Safety Instructions” listed below so as to avoid personnel injury and to prevent product damage.

Products may require specific equipment, and /or installation procedures be carried out to satisfy certain regulatory compliance requirements. Notices have been included in this publication to call attention to these Specific requirements.

Symbol Meanings



This symbol on the equipment refers you to important operating and maintenance (servicing) instructions within the Product Manual Documentation. Failure to heed this information may present a major risk of damage or injury to persons or equipment.



Warning

The symbol with the word “**Warning**” within the equipment manual indicates a potentially hazardous situation, which if not avoided, could result in death or serious injury.



Caution

The symbol with the word “**Caution**” within the equipment manual indicates a potentially hazardous situation, which if not avoided, may result in minor or moderate injury. It may also be used to alert against unsafe practices.



Notice

The symbol with the word “**Notice**” within the equipment manual indicates a situation, which if not avoided, may result in major or minor equipment damage or a situation which could place the equipment in a non-compliant operating state.



**Warning
Hazardous
Voltages**

This symbol is intended to alert the user to the presence of uninsulated "dangerous voltage" within the product enclosure that may be of sufficient magnitude to constitute a risk of shock to persons.



**ESD
Susceptibility**

This symbol is used to alert the user that an electrical or electronic device or assembly is susceptible to damage from an ESD event.

Important Safety Instructions

Read these instructions.
Keep these instructions.
Heed all warnings.
Follow all instructions.



Warning

The safe operation of this product requires that a protective earth connection be provided. A grounding conductor in the equipment's supply cord provides this protective earth. To reduce the risk of electrical shock to the operator and service personnel, this ground conductor must be connected to an earthed ground.

Use only power cords specified for this product and certified for the country of use.

Do not defeat the safety purpose of the grounding-type plug. A grounding type plug has two blades and a third grounding prong. The third prong is provided for your safety. If the provided plug does not fit in to your outlet, consult an electrician for replacement of the obsolete outlet.

Protect the power cord from being walked on or pinching particularly at plugs, convenience receptacles, and point where they exit from the apparatus.



Warning

Indoor Use: "WARNING – TO REDUCE THE RISK OF FIRE OR ELECTRIC SHOCK, DO NOT EXPOSE THIS APPERATUS TO RAIN OR MOISTURE"

Do not use this apparatus near water.

Do not expose this equipment to dripping or splashing and ensure that no objects filled with liquids such as vases are placed on the apparatus.

Do not block any ventilation openings. Install in accordance with manufacturer's instructions.

Do not install near heat sources such as radiators, heat registers, stoves, or other apparatus (including amplifiers) that produce heat.

Only use attachments/accessories specified by the manufacturer.

Unplug this apparatus during lightning storms or when unused for long periods of time.

Clean only with a dry cloth.



Warning

Refer all servicing to qualified personnel. Servicing is required when the apparatus has been damaged in any way, such as power-supply cord or plug damage, liquid has been spilled or objects have fallen into the apparatus, the apparatus has been exposed to rain or moisture, does not operate normally, or has been dropped.



Warning

Certain parts of this equipment still present a safety hazard, with the power switch in the OFF position. To avoid electrical shock, disconnect all A/C power cords from the chassis' rear appliance connectors before servicing.



Caution

To reduce the risk of fire, replacement fuses must be the same type and rating.



Caution

Service barriers within this product are intended to protect the operator and service personnel from hazardous voltages. For continued safety, replace all barriers after servicing.



Warning

This product contains safety critical parts, which if incorrectly replaced may present a risk of fire or electrical shock. Components contained within the product's power supplies and power supply area, are not intended to be customer serviced and should be returned to the factory for repair.

EMC Notices

US FCC Part 15

This equipment has been tested and found to comply with the limits for a class A Digital device, pursuant to part 15 of the FCC Rules. These limits are designed to provide reasonable protection against harmful interference when the equipment is operated in a commercial environment. This equipment generates, uses, and can radiate radio frequency energy and, if not installed and used in accordance with the instruction manual, may cause harmful interference to radio communications. Operation of this equipment in a residential area is likely to cause harmful interference in which case users will be required to correct the interference at their own expense.



Notice

Changes or modifications to this equipment not expressly approved by Ross Video Ltd. could void the user's authority to operate this equipment.

CANADA

This Class "A" digital apparatus complies with Canadian ICES-003.

Cet appareil numérique de classe "A" est conforme à la norme NMB-003 du Canada.

EUROPE

This equipment is in compliance with the essential requirements and other relevant provisions of **CE Directive 93/68/EEC**.

INTERNATIONAL

This equipment has been tested to **CISPR 22:1997** along with amendments **A1:2000** and **A2:2002** and found to comply with the limits for a Class A Digital device.



Notice

This is a Class A product. In domestic environments this product may cause radio interference in which case the user may have to take adequate measures.

Maintenance/User Serviceable Parts

Routine maintenance to this RossGear product is not required. This product contains no user serviceable parts. If the frame does not appear to be working properly, please contact Technical Support using the numbers listed under the "Contact Us" section on the last page of this manual. All RossGear products are covered by a generous 5-year warranty and will be repaired without charge for materials or labor within this period. See the "Warranty and Repair Policy" section in this manual for details.

Environmental Information

The equipment that you purchased required the extraction and use of natural resources for its production. It may contain hazardous substances that could impact health and the environment.

To avoid the potential release of those substances into the environment and to diminish the need for the extraction of natural resources, Ross Video encourages you to use the appropriate take-back systems. These systems will reuse or recycle most of the materials from your end-of-life equipment in an environmentally friendly and health conscious manner.

The crossed-out wheeled bin symbol invites you to use these systems.

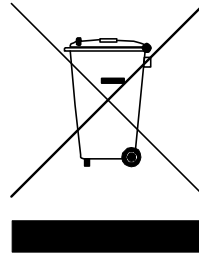

If you need more information on the collection, reuse, and recycling systems, please contact your local or regional waste administration.

You can also contact Ross Video for more information on the environmental performances of our products.

openGear Contents

Introduction	1-1
In This Chapter	1-1
A Word of Thanks	1-1
Overview	1-1
Features	1-2
Documentation Terms	1-3
Installation and Setup	2-1
In This Chapter	2-1
Static Discharge	2-1
Unpacking	2-1
Installing the Frame	2-2
Power Supply PS-8300 and Power Cable	2-2
Fault Reporting	2-3
Improving Performance	2-3
Ventilation and Cooling	2-3
Cable Connections	2-4
Rear I/O Modules	2-5
SMPTE 269M Fault Reporting Option	3-1
In This Chapter	3-1
Overview	3-1
Frame Connections	3-1
Details	3-2
Specifications	4-1
In This Chapter	4-1
Technical Specifications	4-1
Frame Features	5-1
In This Chapter	5-1
Cooling Features	5-2
Installing the Cooling Fan Module	5-2
Cooling Fan Functions and User Controls	5-3
Installing the Controller Card	5-4
Functions of the Controller Card	5-4
Controls and LEDs for the Controller Card	5-5
Remote Control Networking Features	5-7
Installing the Network Controller Card	5-7
Ethernet Setup	5-7
Functions of the Network Controller Card	5-7
Controls and LEDs for the Network Controller Card	5-8
DashBoard and DashBoard Lite Control System Software	5-10

SNMP Monitoring and Control	5-10
Rear Support Bars and Brackets	5-12
Installing the Rear Support Bars and Brackets	5-12
Service Information	6-1
In This Chapter	6-1
Troubleshooting Checklist.....	6-1
Frame Controller Alarm Mute/Bootload Button	6-2
Warranty and Repair Policy	6-2
Ordering Information	7-1
In This Chapter	7-1

Introduction

In This Chapter

This chapter contains the following sections:

- A Word of Thanks
- Overview
- Features
- Documentation Terms

A Word of Thanks

Congratulations on choosing the openGear **DFR-8310 Multi-Definition Digital Products Frame and Power Supply (PS-8300)**. The DFR-8310 is part of a full line of Digital Products within the openGear Terminal Equipment family of products, backed by Ross Video's experience in engineering and design expertise since 1974.

You will be pleased at how easily your new DFR-8310 fits into your overall working environment. Equally pleasing is the product quality, reliability and functionality. Thank you for joining the group of worldwide satisfied Ross Video customers!

Should you have a question pertaining to the installation or operation of your DFR-8310, please contact us at the numbers listed on the back cover of this manual. Our technical support staff is always available for consultation, training, or service.

Overview

The DFR-8310 is a 2RU modular frame, designed to accommodate up to 10 cards of our openGear Multi-Definition product family.

Modular Frame Architecture

The DFR-8310 blends the simplicity of a fixed rear connector frame, and the flexibility of independent rear BNC connector modules.

For most applications which use BNC connectors, the DFR-8310 is available with a fixed 100-BNC rear module. This frame configuration allows any openGear card using only BNC connectors to be installed into any slot, without restrictions. Installation of separate rear modules is not required.

Unused slots can be pre-wired into a facility, and installation of cards can be done at any time without accessing the rear of the frame.

For applications where other types of I/O connections are necessary (such as twisted-pair audio or fiber interfaces), the frame also supports slot-dependent rear modules. Rear modules can be ordered with cards, and are easy and quick to install.

Robust Power Supplies

The DFR-8310 frame can accommodate two front-loaded PS-8300 power supplies. Although a single power supply can fully power a loaded frame, the addition of a second (optional) power supply gives the frame full power redundancy. Each power supply is fed by a separate power cord, which is held in position to guard against accidental power loss.

Each power supply contains an independent cooling fan, status LED, and a front-mounted power switch.

Each frame comes standard with one PS-8300 power supply.

Optional Cooling Fans

The frame has been designed with an advanced cooling architecture to increase ventilation.

For applications where the total card load is less than 40 Watt, the DFR-8310 can be used without cooling fans. Frames should be mounted with 1RU empty space between frames.

For applications where frames are mounted directly above or below other equipment, or where the total card power load is greater than 40 Watt, an optional cooling fan kit must be added. These front-door mounted fans provide forced air cooling for all cards, and additional cooling for the power supplies. An intelligent fan controller adjusts fan speed with changes in frame power loading. Particular attention has been paid to frame acoustics in order to keep fan noise to a minimum.

Additional Frame Accessories

To help reduce mechanical stress due to cable weight, a rear frame support bracket (FSB-8310) is also available.

openGear Cards

The DFR-8310 will accommodate any openGear 8200 series cards.

Important

For long-term reliability and increased product lifespan, total dissipation of all cards installed in a 2RU frame must not exceed 40 Watt total without the use of the Cooling Fan Module. Refer to the section, “**Ventilation and Cooling**”, in this manual, for details.

Features

The following features make the DFR-8310 frame the best solution for standard and high definition terminal equipment:

- 2RU Frame houses up to 10 cards
- Can house any mix of analog, digital, video and audio cards in the same frame
- Available with fixed 100-BNC rear module, or individual card specific modules for connector flexibility
- Heavy-duty hinged front panel lowers to allow easy card insertion
- Durable powder-coat paint finish
- Aluminum construction reduces overall weight
- Two independent looping Reference Inputs feed all card slots

- SMPTE alarm interface for simple monitoring
- Ethernet port for optional networked control
- Robust 150 Watt Power Supply with integral cooling fan
- Optional redundant power supply is hot-swappable for 24/7 operation
- Power switch is accessible from front of the rack frame
- Power supplies are replaceable from the front of the frame without requiring rear-frame access
- Separate power cords to each supply for power feed redundancy
- PowerLock cord retainer mechanism guards against accidental power loss
- Optional Cooling Fan Module for increased ventilation and enhanced reliability
- Fan Fail and Error Indicator LEDs on front of the frame (available with optional Cooling Fan Module)
- Optional Ethernet based Frame Controller for remote setup, monitoring, and control
- 5-year transferable warranty

Documentation Terms

The following terms are used throughout this guide:

- “**Frame**” refers to the **DFR-8310** frames that house the 8200 series cards.
- All references to the **DFR-8310** also include the **DFR-8310-C** versions with the cooling fan option. Refer to the section “**Cooling Features**” for details.
- “**Operator**” and “**User**” both refer to the person who uses the **DFR-8310**.
- “**System**” and “**Video system**” refers to the mix of interconnected digital and analog production and terminal equipment in which the **DFR-8310** operates.

Installation and Setup

In This Chapter

This chapter contains the following sections:

- Static Discharge
- Unpacking
- Installing the Frame
- Power Supply PS-8300 and Power Cable
- Fault Reporting
- Improving Performance
- Ventilation and Cooling
- Cable Connections
- Rear I/O Modules

Static Discharge

Whenever handling the DFR-8310 and other related equipment, please observe all static discharge precautions as described in the following note:



**ESD
Susceptibility**

Static discharge can cause serious damage to sensitive semiconductor devices. Avoid handling circuit boards in high static environments such as carpeted areas, and when wearing synthetic fiber clothing. Always exercise proper grounding precautions when working on circuit boards and related equipment.

Unpacking

Unpack each DFR-8310 you received from the shipping container, and check the contents against the packing list to ensure that all items are included. If any items are missing or damaged, contact your sales representative directly.

Installing the Frame

The DFR-8310 frame mounts in the rack frame by means of four rack screws fastened through the front mounting flanges. This should normally be sufficient to carry the load, including the weight of accompanying cables. However, in certain applications such as mobile truck installations, it may be desirable to also support the rear of the frame. The optional FSB-8310 Rear Support Bars and Brackets are specifically engineered to compensate for extra load stress. Refer to the section “**Installing the Rear Support Bars and Brackets**” of this manual for installation instructions. The Ordering Information section at the end of this manual provides contact information for acquiring this equipment.

Note the following installation requirements:

- **Rack Units:** 2 RU
- **Height:** 3.5 inches (8.89 cm)
- **Depth:** 15.625 inches (40 cm)
- **Rack:** standard 19 inch wide equipment rack

Install the frame for maximum stability during operation and in such a way as to allow adequate ventilation. Ensure that adequate space exists behind the frame and on the right side of the frame for airflow exhaust. The location of the frame should be accessible, dry, and dust free.

Power Supply PS-8300 and Power Cable

The DFR-8310 comes standard with one PS-8300 power supply, with a second optional power supply available for redundancy. For redundancy, and in applications where the equipment is used in a critical signal path, we recommend that two power supplies be used in the DFR-8310 frame. One A/C power cable has been provided with each power supply ordered.

For further redundancy, each power cord should be connected to a separate power source for protection against failure of the A/C power circuit. Reliability will also be improved when using redundant supplies as each supply shares the load. In the event of one power supply failure, card power is seamlessly transferred to the other redundant power supply. Although the power supply is "hot-swappable," turning the power supply off before inserting or removing it from the frame will increase the lifespan of the connectors.

Installing the Frame Power Supply

The power supply plugs into the right-hand section of the chassis. The universal power supply supports all worldwide AC power voltages, and no power adjustments are required. The secondary (redundant) power supply, if ordered, is already installed in the frame.

Use the following procedure to install the power supply:



Warning



**Warning
Hazardous
Voltages**

1. Carefully unpack the power supply from its box, and retain all packing material for future use, if required.
2. Align the power supply into an unused power slot on the right side of the frame.
3. Push the power supply in firmly to ensure a tight connection at the rear of the frame.

Note

In case of a power supply failure, contact your openGear dealer.

The PS-8300 is a power factor corrected supply, capable of working with all world AC standards (100-240V). The supply has an indicator LED on the front, and an error detection circuit that will indicate the conditions described in Table 1.

Table 1. Status LED Descriptions

LED	Color	Display and Description
Fault	Red	When lit, an alarm condition is occurring on a card. (CFM-8310 option)
Fan Fail	Red	When lit, a fan on the frame door or PS-8300 is stalled. (CFM-8310 option)
Power Supply	Green/ Red	When lit green, the PS-8300 is operating normally. When flashing red: <ul style="list-style-type: none"> • there is an output over or under voltage condition on the PS-8300 • there is no A/C; assumed that the second supply is operating normally

Fault Reporting

If the optional CFM-8310 module is installed, the error conditions listed in Table 1 above will trigger the SMPTE 269M fault reporting circuit, and the signal will be sent to the Fault BNC on the back of the frame. Refer to the section “**Fault Report Connector**” in this chapter and the chapter, “**SMPTE 269M Fault Reporting Option**” for further details.

Improving Performance

To improve performance and reliability, the PS-8300 has an on-board fan. Under high load conditions (>40 Watt), the optional CFM-8310 Cooling Fan Module must be added for increased ventilation.

Ventilation and Cooling

This frame has been specially engineered to minimize internal heat buildup and thus improve card reliability. However, for long-term reliability and increased product life of the DFR-8310 frame (without the Cooling Fan Module installed), it is recommended that the total power dissipation of all cards installed in the frame should not exceed 40 Watt, and to leave an empty 1RU panel space above and below the frame for improved heat dissipation. For information on the power dissipation of openGear cards, please refer to the openGear Product Catalog or visit our website.

For applications using less than 40 Watt in a non-ventilated frame, but where the individual card power consumption is greater than 8 Watt, the cards should be evenly distributed in the frame. This will prevent the creation of concentrated heat, or unbalanced heat-rise areas, in the frame.

For applications that require greater heat dissipation, or where the card power consumption is greater than 40 Watt, it is necessary to use the DFR-8310-C frame (with Cooling Fan Module installed), or to install the CFM-8310 Cooling Fan Module field upgrade option. When the Cooling Fan Module is installed, the frame and PS-8300 can supply up to 120 Watt of card power. Under these ventilated conditions, there is **no requirement for extra spacing** between the frames. The DFR-8310-C (or DFR-8310 with CFM-8310 option) can be stacked one on top of the other, a feature that is highly desirable in densely crowded rack frame environments.



Notice

For reliable performance, it is recommended that the frame door not be opened for longer than 5 minutes when using the Cooling Fan Module option on frames loaded with more than 40 Watt.

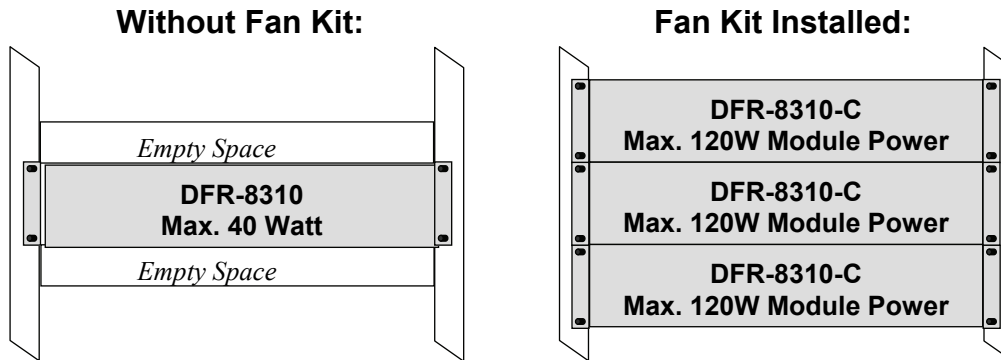

Figure 1. Cooling Fan Module Frame Stacking Options

Cable Connections

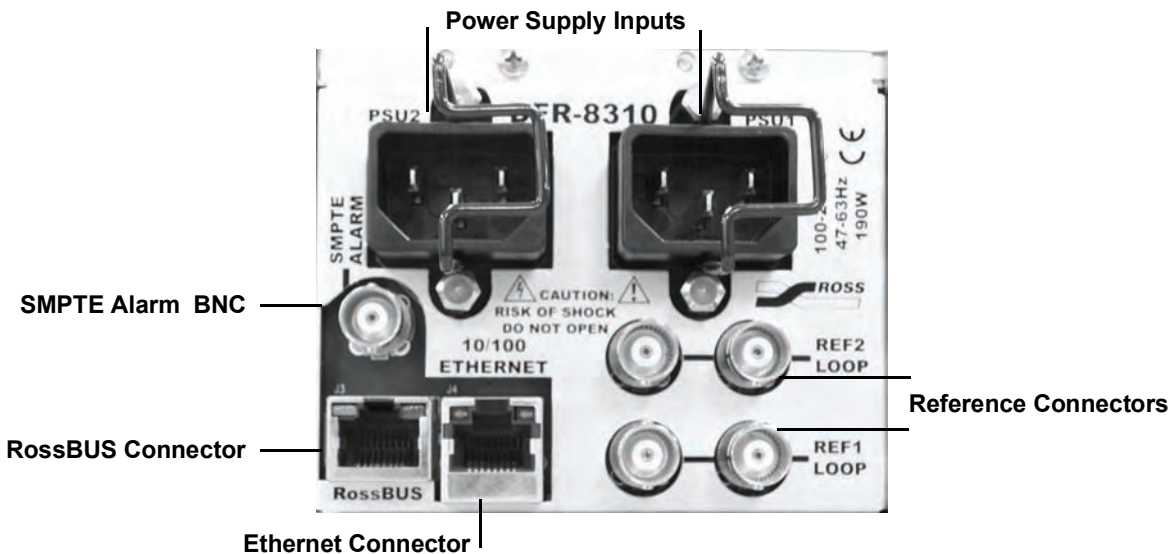

Figure 2. Frame Cable Connectors

Power Cable Connection

Use the following procedure to connect the power cable:

1. Connect the supplied power cable's three prong male connector to an AC outlet.
2. Connect the cable's female IEC connector to the frame socket marked **PSU 1**.
3. If the **Redundant Power Supply** option is installed, repeat step 1 and 2, plugging the second IEC connector into **PSU 2**.

- Each AC connector includes a Powerlock, which is designed to retain the power cable connector. Clip the Powerlock over the shoulder of the inserted AC cable end.



Note — In some countries, it may be necessary to supply the correct mains supply cord. Use only an approved IEC 320 C-13 type A/C line cord rated for a minimum 10A at 250V and certified for the country of use.

Further, the safe operation of this product requires that a protective earth connection be provided. This protective earth is provided by the grounding conductor in the equipment's supply cord. To reduce the risk of electrical shock to operator and service personnel, this ground conductor must be connected to an earthed ground.

Rear I/O Modules

Depending on the frame model you purchased, there may be variations in the BNC Rear I/O Modules connected to it. If the frame was ordered with cards requiring the **DFR-RM-82xx** Rear I/O Module, the appropriate modules will be installed at the factory or included with the card modules.

- DFR-8310** and **DFR-8310-C** frames come without a 100-BNC Rear I/O Module because cards ordered with it require **DFR-RM-82xx** Rear I/O Modules.
- DFR-8310-BNC** and **DFR-8310-C-BNC** frames come with fixed 100-BNC Rear I/O Module.

Consult the installation section of each card's manual for BNC designations. Each card comes with a BNC Label to place on the frame's BNC Rear I/O Module. Each card also has BNC designations printed on the card PCB.

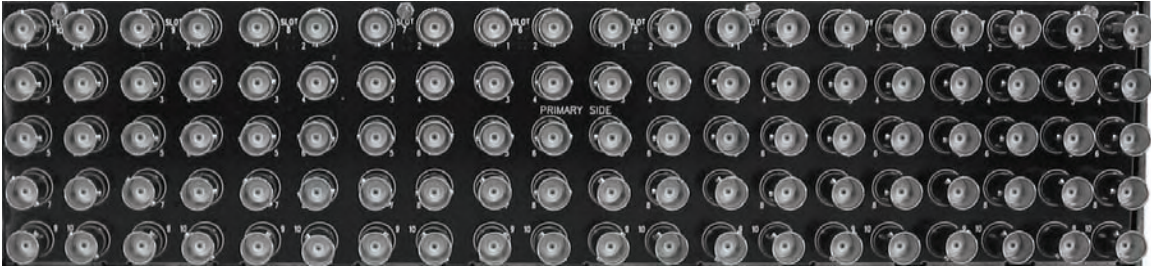

Figure 3. 100 BNC Rear I/O Module



Figure 4. AES-BNC Rear I/O Module



Figure 5. 10 BNC Rear I/O Module



Figure 6. Blank Rear I/O Module

Rear I/O Module Installation

If you are installing an openGear card in a DFR-8310-C-BNC or DFR-8310-BNC frame, skip this section.

If you received a DFR-RM-82xx Rear I/O Module for your openGear card, you will need to install the I/O module in your DFR-8310 frame before you can connect cables.

Use the following procedure to install the DFR-RM-82xx in the DFR-8310 digital distribution frame:

1. Ensure that the frame is properly installed according to instructions in the section “**Installing the Frame**” of this manual.
2. On the rear of the DFR-8310, locate the card frame slot.
3. As shown in Figure 7, seat the bottom of the DFR-RM-82xx in the seating slot at the base of the frame’s back plane.

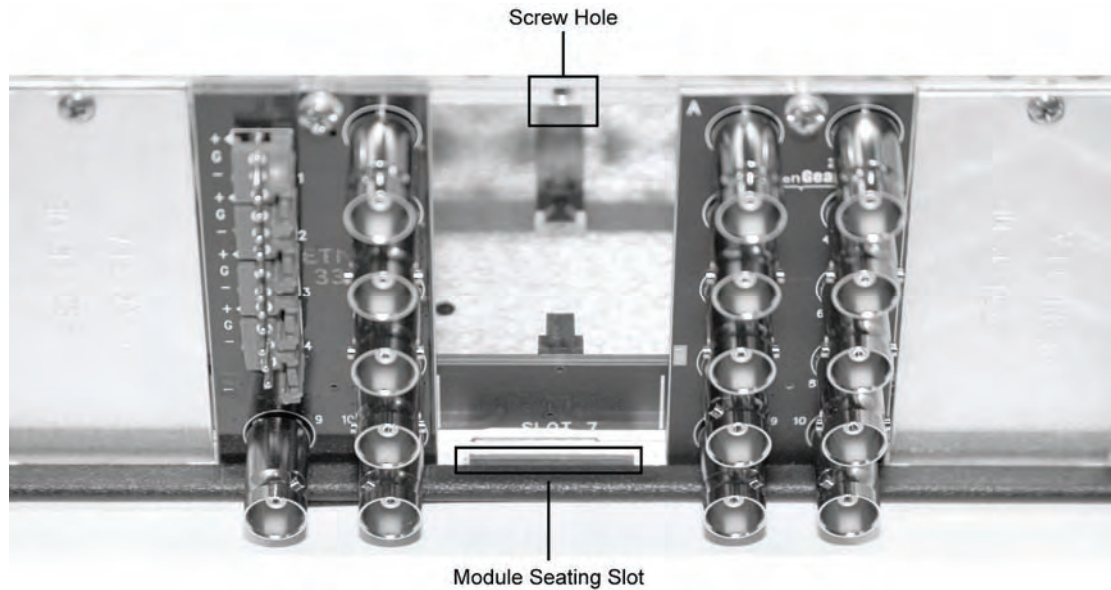

Figure 7. Rear Module Installation

4. Align the top screw of the DFR-RM-82xx with the screw hole on the top edge of the DFR-8310 back plane.
5. Using a Phillips driver and the supplied screw, fasten the DFR-RM-82xx panel to the DFR-8310 back plane. Do not over tighten.
6. Ensure proper frame cooling and ventilation by having all rear frame slots covered with rear I/O modules or blank metal plates. If you need blanks, see the chapter, “**Ordering Information**” and contact your openGear sales representative.

This completes the procedure for installing the DFR-RM-82xx in the DFR-8310 digital distribution frame.

SMPTE Alarm Connector

The SMPTE Alarm BNC connector may be wired to an external alarm system for reporting alarms in SMPTE 269M format. The circuit can drive a 20mA alarm load. For more details on this type of system, refer to the document *ANSI/SMPTE 269M - 1999*, available from SMPTE. Refer also Chapter 3 “**SMPTE Fault Reporting Option**”, in this manual, for further details.

openBUS Connector

This RJ45 connector is used to exchange information data from cards installed in the DFR-8310 frame to an external monitoring/control system. Only cards having the openBUS interface will be able to be monitored and controlled this way. This is reserved for future use with openGear products.



Notice

Connect only openBUS compatible devices and cables on this connector otherwise damage can occur to the frame or to the incompatible device.

Ethernet Connector

This RJ45 connector is used to connect the optional MFC-8310-N frame controller card to an external Ethernet network. This standard 10/100Base-TX RJ45 Ethernet connector is used to exchange information with an external monitoring/control system over an Ethernet network. The optional MFC-8310-N is required to bridge the external Ethernet network to the local openBUS for monitoring and control of cards installed in the DFR-8310 frame. Only cards having the openBUS interface will be able to be monitored and controlled this way.

Note Use up to 100 meters of CAT5 Fast Ethernet cable or better to connect the frame to an external Ethernet hub or switch.

The Ethernet port does not have AutoMDIX support and its RJ45 connector is wired as a Network Interface Card (NIC).

The Ethernet port does not provide Power-over-Ethernet (PoE).

Dual Reference Connectors

Two sets of looping BNC inputs are provided to accept two independent reference signals:

- Analog black
- Tri-level sync
- AES/DARS reference

This feature distributes one or two reference signals to all cards in the frame. Cards which need an external reference use this master reference signal in place of taking the signal from one of the card BNCs. This provides for ease of installation and reduction in reference cabling requirements. If this signal is required, it will be mentioned in the Installation section of the particular card's User Manual.

If only one reference type is required for the frame, connect it to the REF-1 BNC. If the reference is not being looped to another frame or device, ensure that the Loop Ref BNC is terminated.

SMPTE 269M Fault Reporting Option

In This Chapter

This chapter contains the following sections:

- Overview
- Frame Connections
- Details

Overview

The SMPTE 269M Fault Reporting system, also known as a SMPTE “alarm”, provides an indication if one or more frame cards encounter a fault or an abnormal condition. This option is available when an MFC-8310 or MFC-8310-N is installed in the Frame Controller Slot. The MFC-8310 is included if the frame has cooling fans in the front door. The individual card(s) can report fault conditions to the MFC-8310(-N) frame controller card, which in turn outputs to a BNC connector on the openGear DFR-8310 series frame. When the frame connection is interfaced with a customer-designed system of LEDs or audible alarms, faults can be traced to a specific frame when a card fault occurs within that frame.

Frame Connections

The SMPTE 269M Fault Reporting connection on openGear DFR-8310 series frames is provided by the **FAULT** BNC connector, for interfacing with a customer-designed alarm system.

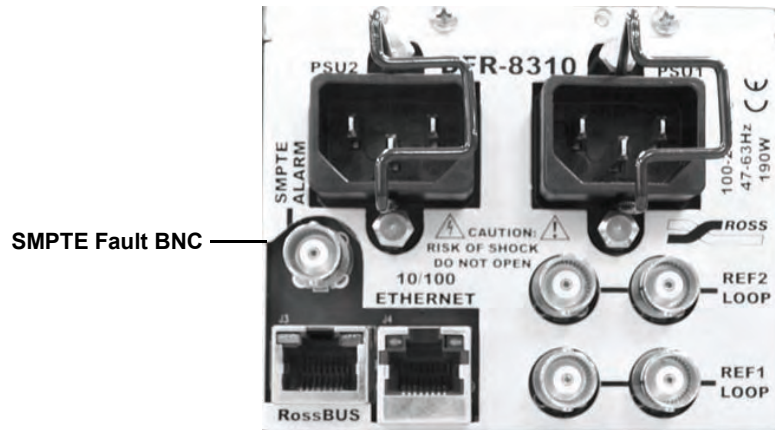

Figure 8. SMPTE 269M Alarm Reporting Frame Connections

Details

The fault report contacts are closed when the card detects an internal failure or a power loss condition. The fault report contacts are closed for about 2 milliseconds every 16 ms to report any error for which SMPTE fault reporting has been enabled.

Some internal failures may include:

- Hardware failure of any card or power supply.
- Loss of AC power to any power supply
- “Soft” errors from any card setup to detect and report such errors

For additional information on alarm system design, refer to the SMPTE document *ANSI/SMPTE 269M - 1999*.

Specifications

In This Chapter

This chapter contains the Technical Specifications table.

Technical Specifications

Table 2. Technical Specifications

Category	Parameter	Specification
PS-8300 Power Supply	Input	100 - 240VAC, 47-63 Hz, 190 Watt
	Output 1	+12V, $\pm 10\%$, 0.5A - 12.5A
	Output 2	-7.5V, $\pm 10\%$, 0A - 2.5A
	Total	Sum of both outputs not to exceed 150 Watt maximum
For safety reasons, Ross power supplies do not fit into rack frames of other manufacturers.		
Rack Frame Mechanical	Height	3.5" (90mm)
	Width	19" (483mm)
	Depth	15.625" (390mm)
	Weight, with 1 PS-8300 installed	10 lbs. (4.5kg)
Frame Card Slots	Number of Slots	10
	Max Power: +12V Rail	1.0A (12 Watt)
	Max Power: -7.5V Rail	0.2A (1.5 Watt)
	Total	120 Watt, total power consumption not to exceed 12W maximum per card slot.
Frame Controller and Fans	Max Power: +12V Rail	1.5A (18 Watt)
	Max Power: -7.5V Rail	0.2A (1.5 Watt)
	Total	19.5 Watt maximum

Category	Parameter	Specification
OpenBUS Remote Power	Max Power: +12V	2.0A (24 Watt), total frame power not to exceed 150W total.
Reference Inputs	Number of Inputs	2 looping
	Level	1Vpp nominal
	Signal	Analog video sync (black burst or tri-level), or AES/EBU DARS
	Impedance	75Ω terminating
	Return Loss	>30dB to 30MHz
	Max DC on Ref Input	±1V
SMPTE Fault Reporting	Alarm Indicator	ANSI/SMPTE 269M-1999 contact closure
	Connector	Female BNC
	Max Voltage	24V DC
	Max Current	20mA
	Alarm Conditions	Loss of AC input power
		DC output voltage error
	PS Monitored Parameters (-C version only)	DC output voltage
		DC output current
		Critical temperature
		PS-8300 fan failure
	Frame Monitored Parameters (-C version only)	Backplane rail voltage
		Cooling fan failure
		Ambient temperature
	Alarm Indicators (-C version only)	System fault LED
		Fan failure LED
Frame controller audio alarm		
Frame door audio alarm		
Environmental	Ambient temperature range	0 °C to 40 °C
	Humidity, non condensing	<95%

Specifications are subject to change without notice.

Important Notes:

The power dissipation of each product installed in this frame is indicated in the Specifications section of the documentation provided with each module. For long-term reliability and increased product life, it is recommended that the total dissipation of all modules installed in a DFR-8310 frame should not exceed 40 Watt total without the CFM-8310, and 120 Watt total with the CFM-8310. In addition, frames without the CFM-8310 should be provided with one rack unit of empty space above and below each frame for ventilation.

Please see the Ventilation and Cooling section in this product's User Manual for further information and options for higher load applications requiring greater heat dissipation.

Frame Features

In This Chapter

This chapter contains the following sections:

- Cooling Features
 - Installing the Cooling Fan Module
 - Cooling Fan Functions and User Controls
 - Installing the Controller Card
 - Functions of the Controller Card
 - Controls and LEDs of the Controller Card
- Remote Control Networking Features
 - Installing the Network Controller Card
 - Ethernet Setup
 - Functions of the Network Controller Card
 - Controls and LEDs of the Network Controller Card
- DashBoard and DashBoard Lite Control System Software
- SNMP Monitoring and Control
- Rear Support Bars and Brackets
 - Installing the Rear Support Bars and Brackets

Cooling Features

The standard DFR-8310 frame can be also be ordered as the DFR-8310-C version, with the Cooling Fan Module installed as original equipment from the factory. However, for customers wishing to increase the ventilation on their standard DFR-8310 frames, the optional CFM-8310 Cooling Fan Module is available as a field upgrade kit.

The CFM-8310 module consists of a fan board, which installs in the frame door, and a controller card, which installs in a designated frame slot. The controller may be either an MFC-8310, which provides fan control and local alarm monitoring, or an MFC-8310-N , which provides fan control, alarm monitoring, and support for remote monitoring and control via Ethernet. Installation instructions are provided in this chapter for both types of controller cards.

Installing the Cooling Fan Module

This section includes instructions on installing the Fan Board component of the CFM-8310 module and an outline of the Functions and User Controls of the module. After you install the CFM-8310 module, you must install the MFC-8310 or the MFC-8310-N controller card.

Fan Board Installation Instructions

Refer to **Figure 9** when installing the Fan Board component of the CFM-8310:

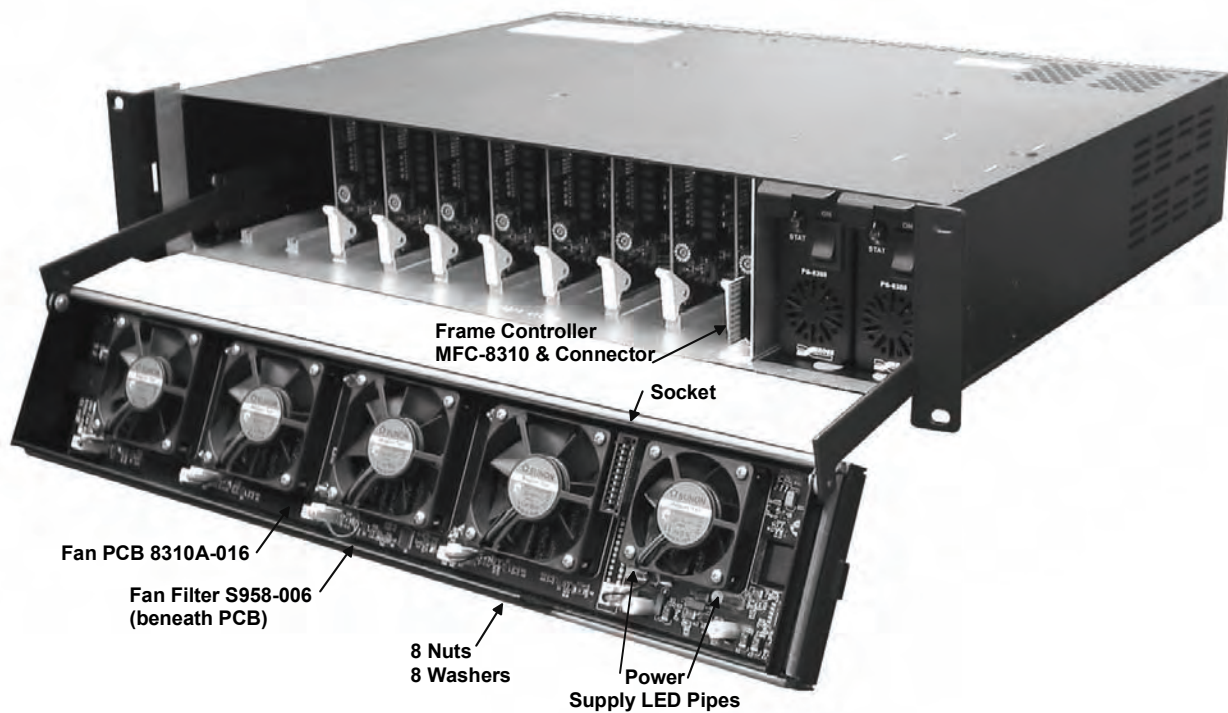

Figure 9. CFM-8310 Cooling Fan Module

Use the following procedure to install the Fan Board component of the CFM-8310:

1. Open the CFM-8310 package and remove the components. Verify that all necessary components are included.
 - Fan PCB 8310A-016

- Fan Filter S985-006
 - 8 nuts 650-007
 - 8 washers 960-025
 - MFC-8310(-N) Frame Controller Card
2. Turn frame power off.
 3. Open the frame door.
 4. Carefully remove the door from the frame by unscrewing the two screws that attach the door to the extender arms.
 5. Place the frame door inside up on a clean antistatic workspace.
 6. Insert the Fan Filter with the panhandle over the smaller fan vents and the cut corner adjacent to the LED pipes already on the door. Gently push the filter down so the mounting bolts pass through cleanly.
 7. Place a washer on each of the 8 mounting bolts.
 8. Align the Fan PCB with the fans up so the LED pipes pass through their board holes.
 9. Ensure the Alarm Mute button clears its door hole and that the Fault and Fan Fail LEDs clear their door holes while you slowly press the Fan PCB down onto the 8 mounting bolts. See Figure 11 for details on these item locations.
 10. On the frame door, check that the Alarm Mute button pushes in and out without binding.
 11. Tighten the 8 nuts until they just make contact with the rubber grommets on the 8310A-016 Fan PCB. Do not over tighten.
 12. Reconnect the door to the frame extender arms with the two screws from step 4.

This completes the procedure to install the Fan Board component of the CFM-8310 module. Next you will learn about the CFM-8310 functions and user controls.

Cooling Fan Functions and User Controls

The CFM-8310 provides LED and Alarm switching controls to the front edge of the DFR-8310 frame door. Refer to Table 4 for details on LED functions for the MFC-8310 controller card. For details on the LED functions for the MFC-8310-N controller card, refer to the section “**Controls and LEDs for the Controller Card**”.



Figure 10. Frame Door Features

Next you will install either an MFC-8310 or an MFC-8310-N controller card. Refer to the appropriate section for installation instructions for your specific controller card.

Installing the Controller Card

Use the following procedure to install the MFC-8310 controller card component of the CFM-8310:



Figure 11. MFC-8310 Fan Controller Card and Unscrewed Retaining Screw

1. With the frame door open, unscrew the MFC-8310 Card Retaining Screw (Part No. 850-040) enough to eliminate any protrusion into the card guide slot on the right of the screw. If necessary, remove any cards from the frame that would interfere with easy access and lines of sight.
2. Insert the MFC-8310 frame controller card, with the component side out as shown in **Figure 11**, into the card guides along the dividing wall between slot 10 and the PS-8300 section of the frame, ensuring the card does not touch the Card Retaining Screw.
3. Slide the card in the slot until firmly seated and so the Card Retaining Screw hole on the bottom front edge aligns with the mounted nut beside the bottom guide slot.
4. Tighten the Card Retaining Screw through the mounted nut and the MFC-8310 Card Retaining Screw hole, to ensure the card does not move from the slot.
5. Close the door, power up the frame, and check the operation of the fans. If the fans do not operate, verify that the MFC-8310 is seated properly in the frame backplane and is aligned to the Fan PCB when the door is closed.

This completes the installation of the MFC-8310 controller card for the CFM-8310 Cooling Fan Module. Next you will learn the general functions and controls available on the MFC-8310 controller card.

Functions of the Controller Card

The MFC-8310 controller card component of the CFM-8310 performs several functions:

- Monitors frame power usage and sets the fan speed accordingly (higher power consumption requires higher fan speed for adequate cooling). The fans always run at maximum speed for 5 seconds after the fan door is closed, then adjust to the appropriate level based on power consumption.
- Monitors the frame door and PS-8300(s) to ensure that fans in all units are operating correctly.

- Monitors the fan door and notifies the user if it is left open too long.
- Monitors the status of other cards in the frame via the internal bus.
- Generates alarms if any of the monitored functions develop errors.

Next you will learn the various controls and LEDs available on the MFC-8310 controller card.

Controls and LEDs for the Controller Card

This section provides information on the jumpers, buttons and LEDs for the MFC-8310 controller card.

The location of the LEDs and controls for fan, alarm, and communication activity are shown in the following figure.

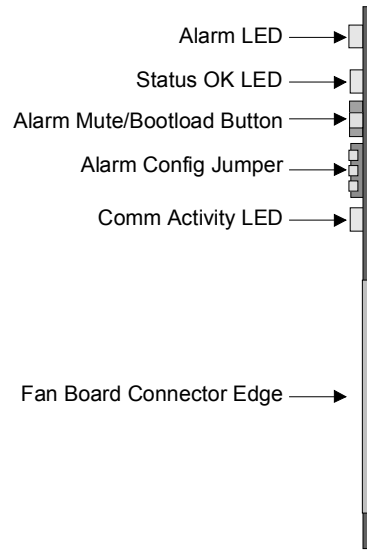

Figure 12. MFC-8310 Card Edge Controls

MFC-8310 Alarm Configuration Jumper

The Alarm Configuration Jumper enables or disables the audio alarm signal. The Alarm LED will still be lit if alarm conditions are occurring, but the audio will be off.

Alarm Mute Button

If the optional CFM-8310 Cooling Fan Module is installed, there is an Alarm Mute Button on the right side of the frame door front. If a card, that is in the frame, is reporting an error, pressing the Alarm Mute Button will mute the audio alarm until another fault condition occurs.

MFC-8310 LEDs

The front edge of the MFC-8310, and the CFM-8310 in the frame door, have LED indicators for cooling module fan, alarm, and communication activity. The CFM-8310 provides LED and Alarm switching controls to the front edge of the DFR-8310 frame door.

LED displays and descriptions are provided in **Table 3**.

Table 3. MFC-8310 Controller Card LED Descriptions

LED	Color	Display and Description
Alarm (MFC-8310)	Red	When lit, an alarm condition is occurring in the frame.
Status OK (MFC-8310)	Green	When lit, the MFC-8310 module is operating correctly.
Comm. Activity (MFC-8310)	Yellow	When lit, the card is communicating within the frame.
Fault (CFM-8310)	Red	When lit, a SMPTE alarm condition is occurring in the frame.
Fan Fail (CFM-8310)	Red	When lit, a fan on the frame door or PS-8300 is stalled.
Power Supply (DFR-8310)	Green/ Red	When lit Green, the PS-8300 is operating normally When flashing Red: <ul style="list-style-type: none"> • there is an output over or under voltage condition on the PS-8300 • there is no A/C; provided that the second supply is operating normally

Remote Control Networking Features

This section includes instructions for installing the MFC-8310-N controller card for the CFM-8310 module.

Installing the Network Controller Card

Perform the physical installation of the MFC-8310-N controller card for the CFM-8310 using the steps provided in the section “**Installing the Controller Card**”. Once the controller card is installed, you can proceed to the section below to set up the Ethernet connection for your card.

Ethernet Setup

Use the following procedure to set up the Ethernet connection for the MFC-8310-N controller card:

1. On the MFC-8310-N card, set DIP_8 to **ON**. Refer to **Figure 13** and **Figure 14** for DIP Switch locations.
2. Power up the MFC-8310-N card. The IP address of the MFC-8310-N card is set to 192.168.1.1 by default.
3. Set the IP Address of your PC to 192.168.1.x, where x is a value other than 1. Consult your IT Department for details.
4. Point your Web browser to 192.168.1.1, the IP Address of the MFC-8310-N card.
5. Set the following parameters as required:
 - **Frame Name** – This name identifies the frame.
 - **DHCP** – Set this parameter to **Yes** if the frame IP Address is to be set automatically.
 - **IP Address** – This is the IP Address, which is supplied by your IT Department, of the card.
 - **NetMask** – This is the subnet mask for your LAN as supplied by your IT Department.
 - **Gateway** – This is the IP Address for connection outside the subnet.
 - **Time Server** – This is the IP Address of the NTP server used as a time source.
 - **Save Changes** – Select this button to send your changes to the MFC-8310-N card. The IP Address of the card is updated.
6. Power down the MFC-8310-N card.
7. On the MFC-8310-N card, set the DIP_8 to **OFF**.
8. Power up the MFC-8310-N. The card will use the configured IP Address.
9. Verify the configured IP Address of the MFC-8310-N card by pointing your Web browser to the new address.

This completes the procedure to configure the network settings for the MFC-8310-N controller card.

Functions of the Network Controller Card

The MFC-8310-N controller card component of the CFM-8310 performs several functions:

- Monitors frame power usage and sets the fan speed accordingly (higher power consumption requires higher fan speed for adequate cooling). The fans always run at maximum speed for 5 seconds after the fan door is closed, then adjust to the appropriate level based on power consumption.
- Monitors the frame door and PS-8300(s) to ensure that fans in all units are operating correctly.
- Monitors the fan door and notifies the user if it is left open too long.
- Monitors the status of other cards in the frame via the internal bus.
- Generates alarms if any of the monitored functions develop errors.
- Provides an Ethernet connection to allow remote monitoring and control of the frame.

Controls and LEDs for the Network Controller Card

This section provides information on the controls and LEDs for the MFC-8310-N controller card. These are similar to the controls and LEDs on the MFC-8310, with some additional LEDs and DIP switches. The location of the controls are show in **Figure 13**.

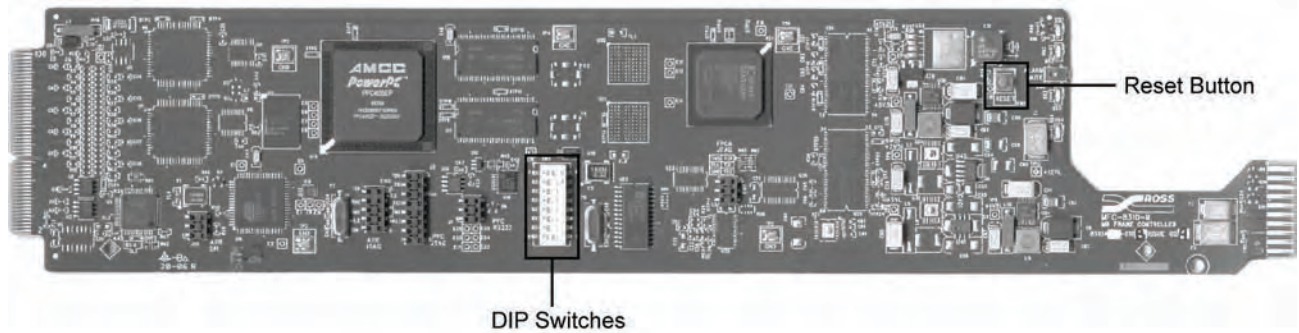

Figure 13. MFC-8310-N DIP Switches

The LED indicators and controls for fan, alarm, and communication activity are shown in **Figure 14**.

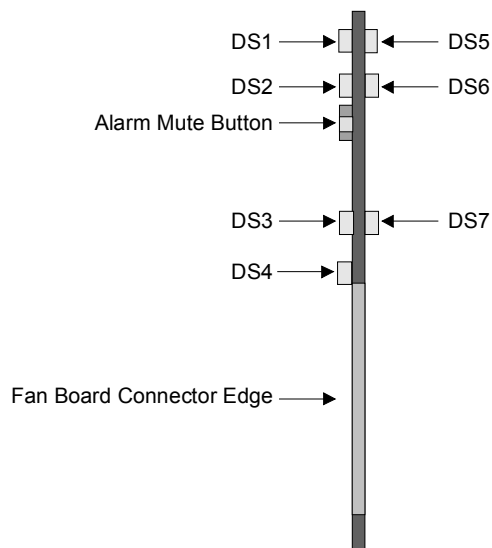

Figure 14. MFC-8310-N Card Edge Controls

DIP Switches on the MFC-8310-N

The following DIP Switches are located on the MFC-8310-N controller card.

DIP_1 Switch

DIP_1 switch enables the audio alarm signal as follows:

- **ON** — This setting enables the audio alarm.
- **OFF** — This setting disables the audio alarm.

DIP_2 to DIP_7 Switches

DIP_2 to DIP_7 switches are not used.

DIP_8 Switch

DIP_8 switch sets the default IP Address of the MFC-8310-N controller card as follows:

- **ON** — This setting enables the card to use the default IP Address of 192.168.1.1.
- **OFF** — This setting enables the card to use the IP Address configured by the user.

Buttons on the MFC-8310-N

The following buttons are located on the MFC-8310-N controller card.

Alarm Mute/Bootload Button

When a card in the frame is reporting an error, pressing the Alarm Mute Button will mute the audio alarm until another fault condition occurs. This button is also used as a bootload button for factory service in the unlikely event of a complete card failure. The bootload process is further described in Chapter 6, “**Service Information**”.

Reset Button

This button is used to restart both of the onboard processors: the fan control processor and the communications processor. The communications processor requires approximately 30 seconds to restart and re-establish network communications.

MFC-8310-N LEDs

The front edge of the MFC-8310-N, and the CFM-8310 in the frame door, have LED indicators for cooling module fan, alarm, and communication activity.

The CFM-8310 provides LED and Alarm switching controls to the front edge of the DFR-8310 frame door. LED displays and descriptions are provided in **Table 4**.

Table 4. MFC-8310-N Controller Card LED Descriptions

LED	Color	Location	Display and Description
Alarm (MFC-8310-N)	Red	DS1	When lit, an alarm condition is occurring in the frame.
Status OK (MFC-8310-N)	Green	DS2	When lit, the fan control process is operating correctly.
Comm. Activity (MFC-8310-N)	Yellow	DS3	When lit, the card is communicating within the frame.
Processor	Red	DS4	This LED flashes red briefly when the card is first powered up. If lit at any other time, this LED indicates that the communications processor is not running.
Error (MFC-8310-N)	Red	DS5	This LED is lit when the MFC-8310-N card is first powered up and the card is booting up. The LED turns off once boot up is complete. If this LED is lit during normal operation, it indicates that the communications software is not running correctly. You must restart the processor by pressing the RESET button.
Transmitting (MFC-8310-N)	Green	DS6	When lit, the MFC-8310-N card is transmitting messages on the internal communications bus.
Receiving (MFC-8310-N)	Yellow	DS7	When lit, the MFC-8310-N card is receiving messages via the internal bus.
Fault (CFM-8310)	Red		When lit, a SMPTE alarm condition is occurring in the frame.
Fan Fail (CFM-8310)	Red		When lit, a fan on the frame door or PS-8300 is stalled.
Power Supply (DFR-8310)	Green/Red		When lit Green, the PS-8300 is operating normally. When flashing Red: <ul style="list-style-type: none"> • there is an output over or under voltage condition on the PS-8300 • there is no A/C; provided that the second supply is operating normally

DashBoard and DashBoard Lite Control System Software

You can use the DashBoard or DashBoard Lite Control Systems to monitor and control your openGear frames and controller cards from a computer. Software and manuals for either DashBoard or DashBoard Lite can be downloaded from the Ross Video website by following the instructions at: www.rossvideo.com/dashboard_lite.html.

SNMP Monitoring and Control

The MFC-8310-N Network Controller card provides optional support for remote monitoring and control of your frame and openGear cards using SNMP (Simple Network Management Protocol),

which is compatible with many third-party monitoring and control tools. This section describes how to enable this feature and how to configure the SNMP software on the card.

Enabling SNMP

You must obtain a license key from Ross Video to enable SNMP support.

Use the following procedure to obtain your license key:

1. Request a license key from your distributor or at sales@rossvideo.com, quoting the 8-character hardware-ID provided on the page.
2. Open the **Frame Configuration Page** for the frame using DashBoard.

OR

Point your web browser to the IP address of the frame.

3. Select the tab titled **SNMP Configuration**. If SNMP has not been enabled, this page will ask you to enter a license key.
4. Enter the license key in the field provided.
5. Click **Submit**. After a valid license key has been entered, the frame displays the SNMP configuration page.

This completes the procedure to enable the SNMP agent on the frame.

Configuring SNMP

The SNMP agent on the frame will accept SNMP GET and SET requests on the default SNMP port (161), using SNMP version 1 or SNMP version 2c. The SNMP commands will send SNMP traps to one or more notification targets, with user-configurable address, port, and protocol version number.

Use the following procedure to configure your SNMP Agent:

1. Open the configuration page for the frame using DashBoard.

OR

Point your web browser to the IP address of the frame.

2. Select the tab titled **SNMP Configuration**.
3. Set the required parameters as follows:
 - **Read Community String** — Enter the SNMP password for GET requests.
 - **Write Community String** — Enter the SNMP password for SET requests.
4. To add a trap/notification target, specify the following:
 - **Target IP address** — Enter the IP address to which traps should be sent.
 - **Port number** — Enter the UDP port number to which traps should be sent.
 - **SNMP version** — Enter the protocol version to be used for traps to this target.
 - **Target community string** — Enter the community string.
5. Click **Add** to add the target to the list.

Operating Tip

To remove a trap/notification target, select the target in the list, and click **Delete**.

6. Click the **Submit** button to configure the frame.

This completes the procedure to configure your SNMP Agent.

Rear Support Bars and Brackets

Under normal conditions, mounting the frame to the front of the rack with four rack screws should be sufficient to carry the load, including the weight of accompanying cables. The optional FSB-8310 Rear Support Bars and Brackets are specifically engineered to compensate for extra load stress associated with certain applications, such as mobile truck installations, to also support the rear of the frame.

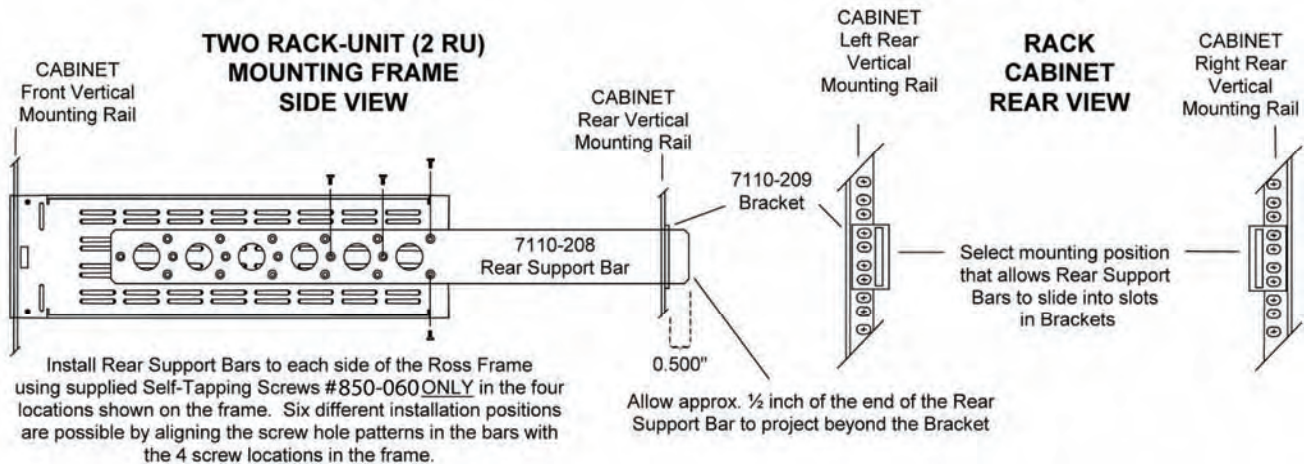

Figure 15. FSB-8310 Rear Support Bars and Brackets Diagram

Installing the Rear Support Bars and Brackets

Use the following procedure to install the FSB-8310 rear support bars and brackets:

1. The rear support bars can be attached to the openGear frame in six possible positions; refer to Figure 15. Choose the position that suits the cabinet depth that will give approximately a ½ inch (0.5") projection beyond the rear vertical mounting rails. Using four screws per bar, as shown in the illustration, fasten one bar to each side of the openGear frame.
2. Mount the openGear frame to the front rails of the rack cabinet using four rack screws fastened through the front mounting flanges.
3. At the rear of the cabinet, slide the bracket slots over the rear of the support bars and secure to the cabinet rear rails with two rack screws each.

This completes the procedure to install the FSB-8310 rear support bars and brackets.

Service Information

In This Chapter

This chapter contains the following sections:

- Troubleshooting Checklist
- Frame Controller Alarm Mute/Bootload Button
- Warranty and Repair Policy

Troubleshooting Checklist

Routine maintenance to this openGear product is not required. In the event of problems with your DFR-8310, the following basic troubleshooting checklist may help identify the source of the problem. If the frame still does not appear to be working properly after checking all possible causes, please contact your openGear products distributor, or the Technical Support department at the numbers listed under the “Contact Us” section at the end of this manual.

1. **Visual Review** – Performing a quick visual check may reveal many problems, such as connectors not properly seated or loose cables. Check the card, the frame, and any associated peripheral equipment for signs of trouble.
2. **Power Check** – Check the power indicator LED on the distribution frame front panel for the presence of power. If the power LED is not illuminated, verify that the power cable is connected to a power source and that power is available at the power main. Confirm that the power supplies are fully seated in their slots. If the power LED is still not illuminated, replace the power supply with one that is verified to work.
3. **Input Signal Status** – Verify that source equipment is operating correctly and that a valid signal is being supplied.
4. **Output Signal Path** – Verify that destination equipment is operating correctly and receiving a valid signal.
5. **Unit Exchange** – Exchanging a suspect unit with a unit that is known to be working correctly is an efficient method for localizing problems to individual units.

Frame Controller Alarm Mute/Bootload Button

In the unlikely event of a complete card failure, you may be instructed by a Ross Technical Support specialist to perform a complete software reload on the MFC-8310 frame controller card.

Use the following procedure to reload the software:

1. Eject the card.
2. Press and hold the Alarm Mute/Bootload button, while re-inserting the card into the frame.
3. Release the button.

The STATUS OK LED will flash GREEN while the card is waiting for a new software load.

If a new software load is not sent to the card within 60 seconds, the card will attempt to restart with its last operational software load.

Software loads can be sent to the MFC-8310 via the connection to the openBUS on the rear of the frame.

Warranty and Repair Policy

The openGear DFR-8310 is warranted to be free of any defect with respect to performance, quality, reliability, and workmanship for a period of FIVE (5) years from the date of shipment from our factory. In the event that your openGear DFR-8310 proves to be defective in any way during this warranty period, Ross Video Limited reserves the right to repair or replace this piece of equipment with a unit of equal or superior performance characteristics.

Should you find that this openGear DFR-8310 has failed after your warranty period has expired, we will repair your defective product should suitable replacement components be available. You, the owner, will bear any labor and/or part costs incurred in the repair or refurbishment of said equipment beyond the FIVE (5) year warranty period.

In no event shall Ross Video Limited be liable for direct, indirect, special, incidental, or consequential damages (including loss of profits) incurred by the use of this product. Implied warranties are expressly limited to the duration of this warranty.

This openGear DFR-8310 User Manual provides all pertinent information for the safe installation and operation of your openGear Product. Ross Video policy dictates that all repairs to the openGear DFR-8310 are to be conducted only by an authorized Ross Video Limited factory representative. Therefore, any unauthorized attempt to repair this product, by anyone other than an authorized Ross Video Limited factory representative, will automatically void the warranty. Please contact Ross Video Technical Support for more information.

In Case of Problems

Should any problem arise with your openGear DFR-8310, please contact the Ross Video Technical Support Department. (Contact information is supplied at the end of this publication.)

A Return Material Authorization number (RMA) will be issued to you, as well as specific shipping instructions, should you wish our factory to repair your openGear DFR-8310. If required, a temporary replacement frame will be made available at a nominal charge. Any shipping costs incurred will be the responsibility of you, the customer. All products shipped to you from Ross Video Limited will be shipped collect.

The Ross Video Technical Support Department will continue to provide advice on any product manufactured by Ross Video Limited, beyond the warranty period without charge, for the life of the equipment.

Ordering Information

In This Chapter

Your DFR-8310 Multi-Definition Digital Products Frame & Power Supply (PS-8300) is a part of the openGear family of products. We offer a full line of openGear terminal equipment including distribution, conversion, monitoring, synchronizers, encoders, decoders, AES, keyers, control switches, as well as analog audio and video products.

Standard Equipment

- **DFR-8310** Digital Products Frame and Power Supply (2RU, holds 10 cards)
- **DFR-8310-C** Digital Products Frame and Power Supply with Cooling Fans (2RU, holds 10 cards)
- **DFR-8310-BNC** Digital Products Frame and Power Supply with fixed 100-BNC Rear Module. (2RU, holds 10 cards)
- **DFR-8310-C-BNC** Digital Products Frame and Power Supply with fixed 100-BNC Rear Module and Cooling Fans. (2RU, holds 10 cards)
- **8310DR-004** Multi-Definition Digital Products Frame & Power Supply (PS-8300) User Manual

Optional Equipment

- **8310DR-004** Multi-Definition Digital Products Frame & Power Supply (PS-8300) User Manual (additional User Manual)
- **PS-8300** openGear Power Supply, 150W (redundancy option power supply for Ross 8310 series 2RU digital product frames)
- **CFM-8310** openGear 2RU Cooling Fan Upgrade Kit (upgrade cooling kit for standard DFR-8310)
- **MFC-8310-N** openGear 2RU Frame Controller with Network Interface (upgrade controller card with Ethernet communication capability)
- **FSB-8310** Rear Support Bars and Brackets (additional support for rear frame-to-rack mounting)
- **DFR-RM-82xx** Rear I/O Modules (card specific module for cable connections)
- **DFR-RM-B1** (8310A-041) Blank Rear I/O Module (cover for unused rear I/O modules)

Notes:

Notes:

Contact Us

Contact our friendly and professional support representatives for the following:

- Name and address of your local dealer
- Product information and pricing
- Technical support
- Upcoming trade show information

PHONE	General Business Office and Technical Support	613 • 652 • 4886
	After-hours Emergency	613 • 349 • 0006
	Fax	613 • 652 • 4425
E-MAIL	General Information	solutions@rossvideo.com
	Technical Support	techsupport@rossvideo.com
POSTAL SERVICE	Ross Video Limited	8 John Street, Iroquois, Ontario, Canada K0E 1K0
	Ross Video Incorporated	P.O. Box 880, Ogdensburg, New York, USA 13669-0880

Visit Us

Please visit us at our website for:

- Company information
- Related products and full product lines
- On-line catalog
- Trade show information
- News
- Testimonials

www.rossvideo.com
