Ross Video Limited

DFR-8300 Series Frames User Manual



**ROSS**
Live Production Technology™

open**Gear**

8300DR-005-02 • DFR-8300 Series Frames User Manual

- Ross Part Number: **8300DR-005-02**
- Release Date: July 9, 2009. Printed in Canada.

The information contained in this manual is subject to change without notice or obligation.

Copyright

© 2009 Ross Video Limited. All rights reserved.

Contents of this publication may not be reproduced in any form without the written permission of Ross Video Limited. Reproduction or reverse engineering of copyrighted software is prohibited.

Notice

The material in this manual is furnished for informational use only. It is subject to change without notice and should not be construed as commitment by Ross Video Limited. Ross Video Limited assumes no responsibility or liability for errors or inaccuracies that may appear in this manual.

Trademarks

-  is a registered trademark of Ross Video Limited.
- Ross, ROSS, ROSS® and MLE are registered trademarks of Ross Video Limited.
- DashBoard Control System™ is a trademark of Ross Video Limited.
- All other product names and any registered and unregistered trademarks mentioned in this guide are used for identification purposes only and remain the exclusive property of their respective owners.

Important Regulatory and Safety Notices

Before using this product and any associated equipment, refer to the “**Important Safety Instructions**” listed below to avoid personnel injury and to prevent product damage.

Products may require specific equipment, and/or installation procedures to be carried out to satisfy certain regulatory compliance requirements. Notices have been included in this publication to call attention to these specific requirements.

Symbol Meanings



This symbol on the equipment refers you to important operating and maintenance (servicing) instructions within the Product Manual Documentation. Failure to heed this information may present a major risk of damage or injury to persons or equipment.



Warning — The symbol with the word “**Warning**” within the equipment manual indicates a potentially hazardous situation which, if not avoided, could result in death or serious injury.



Caution — The symbol with the word “**Caution**” within the equipment manual indicates a potentially hazardous situation which, if not avoided, may result in minor or moderate injury. It may also be used to alert against unsafe practices.



Notice — The symbol with the word “**Notice**” within the equipment manual indicates a situation, which if not avoided, may result in major or minor equipment damage or a situation which could place the equipment in a non-compliant operating state.



Warning Hazardous Voltages — This symbol is intended to alert the user to the presence of uninsulated “dangerous voltage” within the product enclosure that may be of sufficient magnitude to constitute a risk of shock to persons.



ESD Susceptibility — This symbol is used to alert the user that an electrical or electronic device or assembly is susceptible to damage from an ESD event.

Important Safety Instructions

Read these instructions

Keep these instructions.

Heed all warnings

Follow all instructions.



Warning — *The safe operation of this product requires that a protective earth connection be provided. A grounding conductor in the equipment's supply cord provides this protective earth. To reduce the risk of electrical shock to the operator and service personnel, this ground conductor must be connected to an earthed ground.*

Use only power cords specified for this product and certified for the country of use.

Do not defeat the safety purpose of the grounding-type plug. A grounding type plug has two blades and a third grounding prong. The third prong is provided for your safety. If the provided plug does not fit in to your outlet, consult an electrician for replacement of the obsolete outlet.

Protect the power cord from being walked on or pinching particularly at plugs, convenience receptacles, and point where they exit from the apparatus.



Warning — *Indoor Use: "WARNING - TO REDUCE THE RISK OF FIRE OR ELECTRIC SHOCK, DO NOT EXPOSE THIS APPERATUS TO RAIN OR MOISTURE"*

Do not use this apparatus near water.

Do not expose this equipment to dripping or splashing and ensure that no objects filled with liquids such as vases are placed on the apparatus.

Do not block any ventilation openings. Install in accordance with manufacturer's instructions.

Do not install near heat sources such as radiators, heat registers, stoves, or other apparatus (including amplifiers) that produce heat.

Only use attachments/accessories specified by the manufacturer.

Unplug this apparatus during lightning storms or when unused for long periods of time.

Clean only with a dry cloth.



Warning — *Refer all servicing to qualified personnel. Servicing is required when the apparatus has been damaged in any way, such as power-supply cord or plug damage, liquid has been spilled or objects have fallen into the apparatus, the apparatus has been exposed to rain or moisture, does not operate normally, or has been dropped.*



Warning — *Certain parts of this equipment still present a safety hazard, with the power switch in the OFF position. To avoid electrical shock, disconnect all A/C power cords from the chassis' rear appliance connectors before servicing.*



Caution — *To reduce the risk of fire, replacement fuses must be the same type and rating.*



Caution — *Service barriers within this product are intended to protect the operator and service personnel from hazardous voltages. For continued safety, replace all barriers after servicing.*



Warning — *This product contains safety critical parts, which if incorrectly replaced may present a risk of fire or electrical shock. Components contained within the product's power supplies and power supply area, are not intended to be customer serviced and should be returned to the factory for repair.*



Warning — *This product includes an "Ethernet Port" which allows this product to be connected to a local area network (LAN). Only connect to networks that remain inside the building. Do not connect to networks that go outside the building.*

EMC Notices

United States of America FCC Part 15

This equipment has been tested and found to comply with the limits for a class A Digital device, pursuant to part 15 of the FCC Rules. These limits are designed to provide reasonable protection against harmful interference when the equipment is operated in a commercial environment. This equipment generates, uses, and can radiate radio frequency energy and, if not installed and used in accordance with the instruction manual, may cause harmful interference to radio communications. Operation of this equipment in a residential area is likely to cause harmful interference in which case users will be required to correct the interference at their own expense.



Notice — *Changes or modifications to this equipment not expressly approved by Ross Video Limited could void the user's authority to operate this equipment.*

CANADA

This Class “A” digital apparatus complies with Canadian ICES-003.

Cet appareil numérique de la classe “A” est conforme a la norme NMB-003 du Canada.

EUROPE

This equipment is in compliance with the essential requirements and other relevant provisions of **CE Directive 93/68/EEC**.

INTERNATIONAL

This equipment has been tested to **CISPR 22:1997** along with amendments **A1:2000** and **A2:2002**, and found to comply with the limits for a Class A Digital device.



Notice — *This is a Class A product. In domestic environments, this product may cause radio interference, in which case the user may have to take adequate measures.*

Maintenance/User Serviceable Parts

Routine maintenance to this openGear product is not required. This product contains no user serviceable parts. If the module does not appear to be working properly, please contact Technical Support using the numbers listed under the “Contact Us” section on the last page of this manual. All openGear products are covered by a generous 5-year warranty and will be repaired without charge for materials or labor within this period. See the “Warranty and Repair Policy” section in this manual for details.

Environmental Information

The equipment that you purchased required the extraction and use of natural resources for its production. It may contain hazardous substances that could impact health and the environment.

To avoid the potential release of those substances into the environment and to diminish the need for the extraction of natural resources, Ross Video encourages you to use the appropriate take-back systems. These systems will reuse or recycle most of the materials from your end-of-life equipment in an environmentally friendly and health conscious manner.

The crossed-out wheeled bin symbol invites you to use these systems.



If you need more information on the collection, reuse, and recycling systems, please contact your local or regional waste administration. You can also contact Ross Video for more information on the environmental performances of our products.

Company Address



Ross Video Limited

8 John Street
Iroquois, Ontario
Canada, K0E 1K0

Ross Video Incorporated

P.O. Box 880
Ogdensburg, New York
USA 13669-0880

General Business Office: (+1) 613 • 652 • 4886

Fax: (+1) 613 • 652 • 4425

Technical Support: (+1) 613 • 652 • 4886

After Hours Emergency: (+1) 613 • 349 • 0006

E-mail (Technical Support): techsupport@rossvideo.com

E-mail (General Information): solutions@rossvideo.com

Website: <http://www.rossvideo.com>



Contents

Introduction	1
Overview.....	1-2
Features.....	1-3
DFR-8310 Series Frames	1-3
DFR-8321 Series Frames	1-3
Documentation Terms and Conventions.....	1-4
Installation	2
Before You Begin.....	2-2
Installing a DFR-8300 Series Frame	2-3
DFR-8300 Series Frame Overview	2-3
Rear Support Bars and Brackets	2-4
Installing the Rear Support Bars and Brackets.....	2-4
COMM I/O Overview.....	2-5
Power Supply PS-8300 and Power Cable.....	2-8
Power Supply Connectors (PSU1, PSU2).....	2-8
Installing the Frame Power Supply	2-8
Power Cable Connection	2-9
Fault Reporting	2-10
Ventilation and Cooling.....	2-11
DFR-8310 Series Frames	2-11
DFR-8321 Series Frames	2-11
Rear Module Installation	2-12
Network Connections	2-14
DFR-8310 Series Setup	3
Rear Modules for the DFR-8310 Series Frames.....	3-2
SMPTE Fault Reporting Option	3-3
Frame Connections.....	3-3
Details.....	3-3
Cooling Features.....	3-4
Installing the Cooling Fan Module.....	3-4
Cooling Fan Functions and User Controls	3-5
Specifications for the DFR-8310 Series Frames.....	3-6
DFR-8321 Series Setup	4
Rear Modules for the DFR-8321 Series Frames.....	4-2
Full Rear Module.....	4-2
Split Rear Module	4-2
Cooling Features.....	4-3
Cooling Fan Functions and User Controls	4-3
Replacing the CFM-8321 Cooling Fan Module.....	4-3
Specifications for the DFR-8321 Series Frames.....	4-4

Service Information

5

Troubleshooting Checklist.....	5-1
Warranty and Repair Policy.....	5-2

Introduction

In This Chapter

This chapter contains the following sections:

- A Word of Thanks
- Overview
- Features
- Documentation Terms and Conventions

A Word of Thanks

Congratulations on choosing an openGear DFR-8300 series frame. Your DFR-8300 series frame is part of a full line of Digital Products within the openGear Terminal Equipment family of products, backed by Ross Video's experience in engineering and design expertise since 1974.

You will be pleased at how easily your new DFR-8300 series frame fits into your overall working environment. Equally pleasing is the product quality, reliability and functionality. Thank you for joining the group of worldwide satisfied Ross Video customers!

Should you have a question pertaining to the installation or operation of your DFR-8300 series frame, please contact us at the numbers listed on the back cover of this manual. Our technical support staff is always available for consultation, training, or service.

Overview

Your DFR-8300 series frame is a 2RU modular frame, designed to accommodate any openGear card. A complete list of available openGear cards is available on our website.

Modular Frame I/O

The DFR-8310 series frame is available pre-installed with ten 10-BNC rear modules and the flexibility of independent rear BNC connector modules.

For most applications which use BNC connectors, the DFR-8310 series frame configuration allows any openGear card using only BNC connectors to be installed into any slot, without restrictions. Installation of separate Rear Modules is not required. Unused slots can be pre-wired into a facility, and installation of cards can be done at any time without accessing the rear of the frame.

For applications where other types of I/O modules are necessary (such as twisted-pair audio or fiber interfaces), the frame also supports module-dependent Rear Modules. Rear modules can be ordered with cards, and are easy and quick to install.

The DFR-8321 series frame supports module dependent rear modules.

Robust Power Supplies

The DFR-8300 series frame can accommodate two front-loaded PS-8300 power supplies. Although a single power supply can fully power a loaded frame, the addition of a second (optional) power supply gives the frame full power redundancy. Each power supply is fed by a separate power cord, which is held in position to guard against accidental power loss.

Each power supply contains an independent cooling fan, status LED, and a front-mounted power switch.

Each frame comes standard with one PS-8300 power supply.

Optional Cooling Fans

The DFR-8300 series frame has been designed with an advanced cooling architecture to increase ventilation. An intelligent fan controller adjusts fan speed with changes in frame power loading. Particular attention has been paid to frame acoustics in order to keep fan noise to a minimum.

- **DFR-8310 series frames** — For applications where the total card load is less than 40W, the DFR-8310 series frame can be used without cooling fans. Frames should be mounted with 1RU empty space between frames. For applications where frames are mounted directly above or below other equipment, or where the total card power load is greater than 40W, an optional cooling fan kit must be added. These front-door mounted fans provide forced air cooling for all cards, and additional cooling for the power supplies.
- **DFR-8321 series frames** — The frame has been designed with an advanced cooling architecture to increase ventilation. These front-door mounted fans provide forced air cooling for all cards, and additional cooling for the power supplies.

Additional Frame Accessories

To help reduce mechanical stress due to cable weight, a rear frame support bracket (FSB-8310) is available for the DFR-8310 series frames. The rear support bracket (FSB-8320) is for the DFR-8321 series frames.

Features

The following features make the DFR-8300 series frames the best solution for standard and high definition terminal equipment:

- Aluminum construction reduces overall weight
- Two independent looping Reference Inputs feed all card slots
- Can house any mix of analog, digital, video and audio cards in the same frame
- Available with individual card specific modules for connector flexibility
- Ethernet port for optional network control
- Robust 150W Power Supply with integral cooling fan
- Optional redundant power supply is hot-swappable for 24/7 operation
- Power switch is accessible from front of the rack frame
- Power supplies are replaceable from the front of the frame without requiring rear-frame access
- Separate power cords to each supply for power feed redundancy
- PowerLock cord retainer mechanism guards against accidental power loss
- Optional Cooling Fan Module for increased ventilation and enhanced reliability
- Fan Fail and Error Indicator LEDs on front of the frame (available with optional Cooling Fan Module)
- Optional Ethernet based Frame Controller for remote setup, monitoring, and control
- 5-year transferable warranty

DFR-8310 Series Frames

In addition to the standard features, the following additional features are available on the DFR-8310 series frame:

- 2RU Frame houses up to 10 cards
- Heavy-duty hinged front door lowers to allow easy card insertion
- Durable powder-coat paint finish
- SMPTE alarm interface for simple monitoring

DFR-8321 Series Frames

In addition to the standard features, the following additional features are available on the DFR-8321 series frames:

- 2RU Frame houses up to 20 cards
- Supports all existing rear modules designed for the DFR-8320 series frames
- Removable hinged front door for easy card insertion and removal, and flexibility in servicing the cooling fans
- Rack mount ears are steel for extra strength
- Removable door with durable powder-coat paint finish

Documentation Terms and Conventions

The following terms and conventions are used throughout this manual:

- “**Frame**” refers to any openGear frame within your video system.
- All references to the **DFR-8300 series frame** also includes all version of the 10-slot (DFR-8310 series) and 20-slot (DFR-8321 series frame series) frames and any available options unless otherwise noted.
- All references to the **MFC-8310-N Network Controller Card** also includes the MFC-8310-NS unless otherwise indicated.
- All references to the **MFC-8320-N Network Controller Card** also includes the MFC-8320-NS unless otherwise indicated.
- “**Network Controller Card**” refers to the MFC-8310-N, MFC-8310-NS, MFC-8320-S, MFC-8320-N, and MFC-8320-NS unless otherwise indicated.
- “**Operator**” and “**User**” refer to the person who uses the DFR-8300 series frame.
- “**Board**”, and “**Card**” refer to openGear terminal devices within openGear frames, including all components and switches.
- “**System**” and “**Video system**” refer to the mix of interconnected production and terminal equipment in your environment.
- The “**Operating Tips**” and “**Note**” boxes are used throughout this manual to provide additional user information.

Installation

In This Chapter

This chapter provides basic instructions for installing the DFR-8300 series frame.

The following topics are discussed:

- Before You Begin
- Installing a DFR-8300 Series Frame
- Rear Support Bars and Brackets
- COMM I/O Overview
- Power Supply PS-8300 and Power Cable
- Ventilation and Cooling
- Rear Module Installation
- Network Connections

Before You Begin

Before proceeding with the instructions in this chapter, ensure that you read the following sections.

Static Discharge

Throughout this chapter, please heed the following cautionary note:



ESD Susceptibility — *Static discharge can cause serious damage to sensitive semiconductor devices. Avoid handling circuit boards in high static environments such as carpeted areas and when synthetic fiber clothing is worn. Always exercise proper grounding precautions when working on circuit boards and related equipment.*

Unpacking

Unpack each DFR-8300 series frame you received from the shipping container and ensure that all items are included. If any items are missing or damaged, contact your sales representative or Ross Video directly.

Installing a DFR-8300 Series Frame

This section outlines how to install a DFR-8300 series frame. The same procedure is used to install a frame regardless of the model of frame unless otherwise noted.

DFR-8300 Series Frame Overview

The DFR-8300 series frame mounts in the rack frame by means of four rack screws fastened through the front mounting ears. This should normally be sufficient to carry the load, including the weight of accompanying cables. However, in certain applications such as mobile truck installations, it may be desirable to also support the rear of the frame. The optional Rear Support Bars and Brackets are specifically engineered to compensate for extra load stress. Refer to the section “**Rear Support Bars and Brackets**” on page 2-4 for installation instructions.

Note that the frame installs in a standard 19” rack:

- Rack Units: 2 RU
- Height: 3.5” (8.89cm)
- Depth:
 - › DFR-8310 frames — 15.625” (40cm)
 - › DFR-8321 frames — 17” (43.18cm)
- Width: 19” (48.26cm)

Install the frame for maximum stability during operation and in such a way as to allow adequate ventilation. Ensure that adequate space exists behind the frame and on the right side of the frame for airflow exhaust. The location of the frame should be accessible, dry, and dust-free.

Rear Support Bars and Brackets

Under normal conditions, mounting the frame to the front of the rack with four rack screws should be sufficient to carry the load, including the weight of accompanying cables. The optional **Rear Support Bars and Brackets (FSB-8310 or FSB-8320)** are specifically engineered to compensate for extra load stress associated with certain applications, such as mobile truck installations, to also support the rear of the frame.

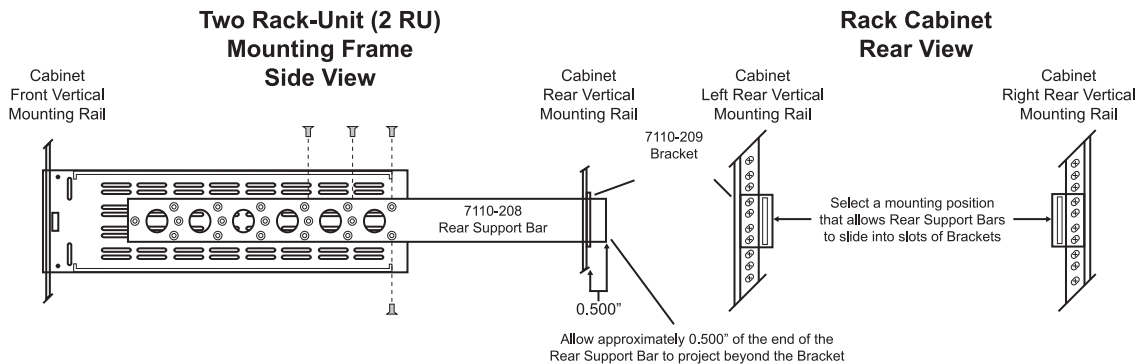

Figure 2.1 Rear Support Bars and Brackets Diagram

Installing the Rear Support Bars and Brackets

The rear support bars can be attached to the openGear frame in six possible positions; refer to **Figure 2.1**.

Use the following procedure to install the rear support bars and brackets:

1. Choose the position that suits the cabinet depth that will give approximately a ½ inch (0.5") projection beyond the rear vertical mounting rails.
2. Install a Rear Support Bars to each side of the Ross Frame using the supplied screws in the four locations as shown in **Figure 2.1**.
 - Fasten one bar to each side of the openGear frame.
 - Six different installation positions are possible by aligning the screw hole patterns in the bars with the four screw locations in the frame.
 - Use only the supplied screws.
3. Mount the openGear frame to the front rails of the rack cabinet using four rack screws fastened through the front mounting flanges.
4. At the rear of the cabinet, slide the bracket slots over the rear of the support bars
5. Secure to the cabinet rear rails with two rack screws each.

This completes the procedure to install the rear support bars and brackets.

COMM I/O Overview

The **COMM I/O** includes all the communication connectors for the DFR-8300 series frame control and frame-wide references. The COMM I/O is located at the back of the frame near the power supplies.

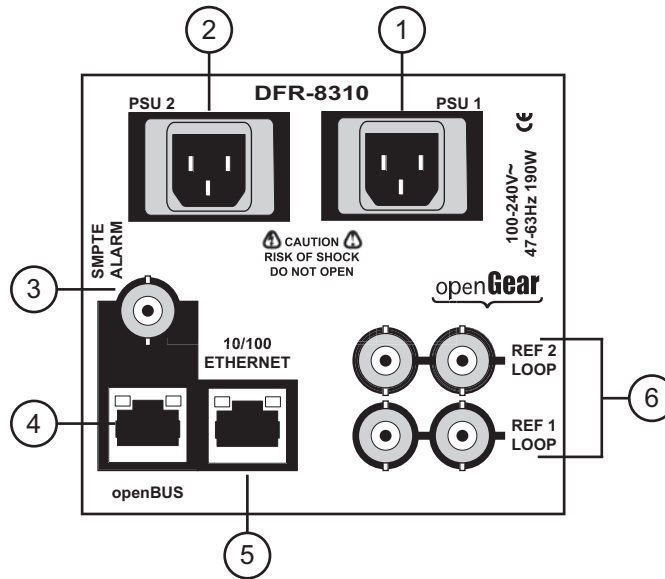

Figure 2.2 DFR-8310 Series Frames — COMM I/O

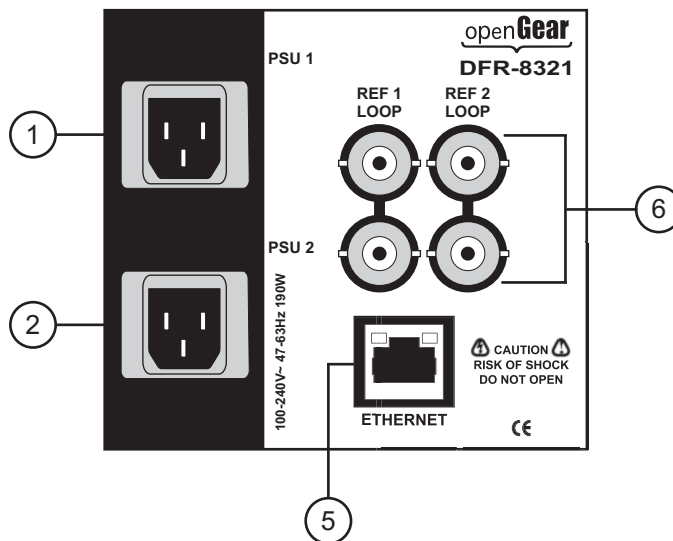

Figure 2.3 DFR-8321 Series Frames — COMM I/O

- | | | |
|--------------------------------|-------------------------------|--------------------------------|
| 1) PSU1 Power Supply Connector | 3) SMPTE Alarm BNC | 5) Ethernet Communication Port |
| 2) PSU2 Power Supply Connector | 4) openBus Communication Port | 6) Reference Connectors |

1. PSU1 Power Supply Connector

This connector is the AC Connector for the main power supply.

2. PSU2 Power Supply Connector

This connector is the AC Connector for the redundant power supply.

3. SMPTE Alarm BNC (DFR-8310 Series Frames only)

The SMPTE 269M Fault Reporting connection on openGear DFR-8310 series frames is provided by the FAULT BNC connector, for interfacing with a customer-designed alarm system. Refer to the section “SMPTE Fault Reporting Option” on page 3-3 for details.

4. openBus Communication Port (DFR-8310 Series Frames only)

This feature is not implemented. Do not connect to this port.

5. Ethernet Communication Port

An optional Network Controller card is required to bridge the external Ethernet network to the local communication bus for monitoring and control of cards installed in the DFR-8321 frame. Only cards having the Communication bus interface will be able to be monitored and controlled this way. For details on installing and configuring a Network Controller Card, refer to the *MFC-8300 Series User Manual*.



Note — *The MFC-8310-N and MFC-8310-NS do not support Auto-MDIX.*

The Ethernet Connector is an RJ45 connector is used to connect the optional Network Controller card to an external Ethernet network. This standard 10/100Base-TX RJ45 Ethernet connector is used to exchange information with an external monitoring, or control, system over an Ethernet network. Refer to **Table 2.1** for wiring information.



Note — *Use CAT5 Fast Ethernet cable or better (up to 100m) to connect the frame to an external Ethernet hub or switch. The Ethernet port has its RJ45 connector wired as a Network Interface Card (NIC). The Ethernet port does not provide Power-over-Ethernet (PoE).*

Table 2.1 Ethernet Port Pinouts

Pin Number	Signal
1	Tx+
2	Tx-
3	Rx+
4	*
5	*
6	Rx-
7	†
8	†

* Shorted, 75ohm to Ground

† Shorted, 75ohm to Ground

6. Reference Connectors

Two sets of looping BNC inputs are provided to accept two independent reference signals supporting the following reference signal types:

- Analog black
- Tri-level sync
- AES/DARS reference

This feature distributes one or two reference signals to all cards in the frame. Cards which need an external reference use this master reference signal in place of taking the signal from one of the card BNCs. This provides for ease of installation and reduction in reference cabling requirements. If this signal is required, it will be mentioned in the “**Installation**” section of the card *User Manual*.

If only one reference type is required for the frame, connect it to the **REF-1 BNC**. If the reference is not being looped to another frame or device, ensure that the **Loop Ref BNC** is terminated.

Power Supply PS-8300 and Power Cable

The DFR-8300 series frame comes standard with one PS-8300 power supply, with a second optional power supply available for redundancy. For redundancy, and in applications where the equipment is used in a critical signal path, we recommend that two power supplies be used in the DFR-8300 series frame. One A/C power cable has been provided with each power supply ordered.



Notice — *To improve performance and reliability, the PS-8300 has an on-board fan. Under high load conditions (>40W), the optional CFM-8310 Cooling Fan Module must be added for increased ventilation.*

For further redundancy, each power cord should be connected to a separate power source for protection against failure of the A/C power circuit. Reliability will also be improved when using redundant supplies as each supply shares the load. In the event of one power supply failure, the frame load is seamlessly transferred to the other redundant power supply. Although the power supply is “hot-swappable” turning the power supply off before inserting or removing it from the frame will increase the life span of the connectors.

Power Supply Connectors (PSU1, PSU2)

There are two power supply connectors located on the back of the DFR-8300 series frame:

- **PSU1** — This connector is designated as the AC Connector for the main power supply.
- **PSU2** — This connector is designated as the AC Connector for the redundant power supply.

Installing the Frame Power Supply

The power supply plugs into the right-hand section of the chassis. The universal power supply supports all worldwide AC power voltages, and no power adjustments are required. The secondary (redundant) power supply, if ordered, is already installed in the frame.

Use the following procedure to install the power supply:

1. Carefully unpack the power supply from its box, and retain all packing material for future use, if required.
2. Align the power supply into an unused power slot on the right side of the frame.
3. Push the power supply in firmly to ensure a tight connection at the rear of the frame.

The PS-8300 is a power factor corrected supply, capable of working with all world AC standards (100-240V). The supply has an indicator LED on the front, and an error detection circuit that will indicate the conditions described in **Table 2.2**.

Power Cable Connection

This section includes information for connecting the power cables for the DFR-8300 series frames.



Warning Hazardous Voltages — *The safe operation of this product requires that a protective earth connection be provided. This protective earth is provided by the grounding conductor in the equipment's supply cord. To reduce the risk of electrical shock to operator and service personnel, this ground conductor must be connected to an earthed ground.*



Warning — *In some countries, it may be necessary to supply the correct mains supply cord. Use only an approved IEC 320 C-13 type A/C line cord rated for a minimum 10A at 250V and certified for the country of use.*

Use the following procedure to connect the power cables for a DFR-8300 series frame:

1. Connect the cable's female IEC connector to the frame socket marked **PSU 1** (**Figure 2.2** and **Figure 2.3**).
2. If the **Redundant Power Supply** option is installed, plug the second IEC connector into **PSU 2** (**Figure 2.2** and **Figure 2.3**).
3. Each AC connector includes a PowerLock, which is designed to retain the power cable connector. Clip the PowerLock over the shoulder of the inserted AC cable end.
4. Connect the supplied power cable's three-prong male connector to an AC outlet.

This completes the procedure for connect the power cables to a DFR-8300 series frame.

Fault Reporting

If the optional CFM-8310 module is installed, the error conditions listed in **Table 2.2** will trigger the SMPTE 269M fault reporting circuit, and the signal will be sent to the SMPTE Alarm BNC on the back of the frame. The SMPTE 269M fault reporting option is only available for the DFR-8310 frames.

Table 2.2 Status LED Descriptions

Location	LED	Color	Description
Frame Door	FAULT	Red	When lit, this LED indicates that an alarm condition is occurring on a card. This comes standard for the DFR-8321 series frames, and with the CFM-8310 option in the DFR-8310 series frames.
Frame Door	FAN FAIL	Red	When lit, this LED indicates that a fan on the frame or on the PS-8300 is stalled. This comes standard for the DFR-8321 series frames, and with the CFM-8310 option in the DFR-8310 series frames.
Power Supply	STAT	Green	When lit green, this LED indicates that the PS-8300 is operating normally.
		Red	When flashing red, this LED indicates: <ul style="list-style-type: none">• there is an output over, or under, voltage conditions on the PS-8300.• there is no power; assuming that the second supply is operating normally.

For More Information...

- on the SMPTE 269M fault reporting option in a DFR-8310 series frame, refer to the section “**SMPTE Fault Reporting Option**” on page 3-3.

Ventilation and Cooling

This frame has been specially engineered to minimize internal heat buildup and thus improve card reliability. However, for long-term reliability and increased product life of the DFR-8310 frame (without the Cooling Fan Module installed), it is recommended that the total power dissipation of all cards installed in the frame should not exceed 40W, and to leave an empty 1RU panel space above and below the frame for improved heat dissipation. For information on the power dissipation of openGear cards, refer to the openGear Product Catalog or visit our website.

For applications using less than 40W in a non-ventilated frame, but where the individual card power consumption is greater than 8W, the cards should be evenly distributed in the frame. This will prevent the creation of concentrated heat, or unbalanced heat-rise areas, in the frame.



Ross Video recommends that you periodically clean the filter in the frame door to maintain optimal airflow and cooling through the frame. Open the door, for no longer than 5 minutes, and use a vacuum to clean the filter. Never use water or other cleaning agents to wash the filter.

DFR-8310 Series Frames

For applications that require greater heat dissipation, or where the card power consumption is greater than 40W, it is necessary to use the DFR-8310-C frame (with Cooling Fan Module installed), or to install the CFM-8310 Cooling Fan Module field upgrade option. When the Cooling Fan Module is installed, the frame and PS-8300 can supply up to 120W of card power. Under these ventilated conditions, there is no requirement for extra spacing between the frames. The DFR-8310-C (or DFR-8310 with CFM-8310 option) can be stacked one on top of the other, a feature that is highly desirable in densely crowded rack frame environments.



Notice — *For reliable performance, it is recommended that the frame door not be opened for longer than 5 minutes when using the Cooling Fan Module option on frames loaded with more than 40W.*

DFR-8321 Series Frames

The DFR-8321 series frames come standard with a Cooling Fan Module. The frame and PS-8300 can supply up to 120W of card power. Under these ventilated conditions, there is no requirement for extra spacing between the frames. The DFR-8321 series frames can be stacked one on top of the other, a feature that is highly desirable in densely crowded rack frame environments.



Notice — *For reliable performance, it is recommended that the frame door not be opened for longer than 5 minutes on frames loaded with more than 40W.*

For More Information...

- on installing the CFM-8310 Cooling Fan Module in the DFR-8310 series frames, refer to the section “**Installing the Cooling Fan Module**” on page 3-4.
- on the Cooling Features for the DFR-8321 series frames, refer to the section “**Cooling Fan Functions and User Controls**” on page 4-3.

Rear Module Installation

If you are installing an openGear card in a DFR-8310-C-BNC or DFR-8310-BNC frame, skip this section. If you received a Rear Module for your openGear card, you will need to install the module in your DFR-8300 series frame before you can connect cables.

Use the following procedure to install a Rear Module in a DFR-8300 series frame:

1. Power down the frame.
2. Ensure that the frame is properly installed.
3. If you are installing a Rear Module in a DFR-8310 series frame:
 - On the rear of the DFR-8300 series frame, locate the card frame slot.
4. If you are installing a Rear Module in a DFR-8321 series frame:
 - When installing a Full Rear Module, you must select an even-numbered slot, such as 2, 4 or 6.
 - When installing a Split Rear Module, remember that this module requires two slots.
5. Seat the bottom of the Rear Module in the seating slot at the base of the frame back plane. (**Figure 2.4**)

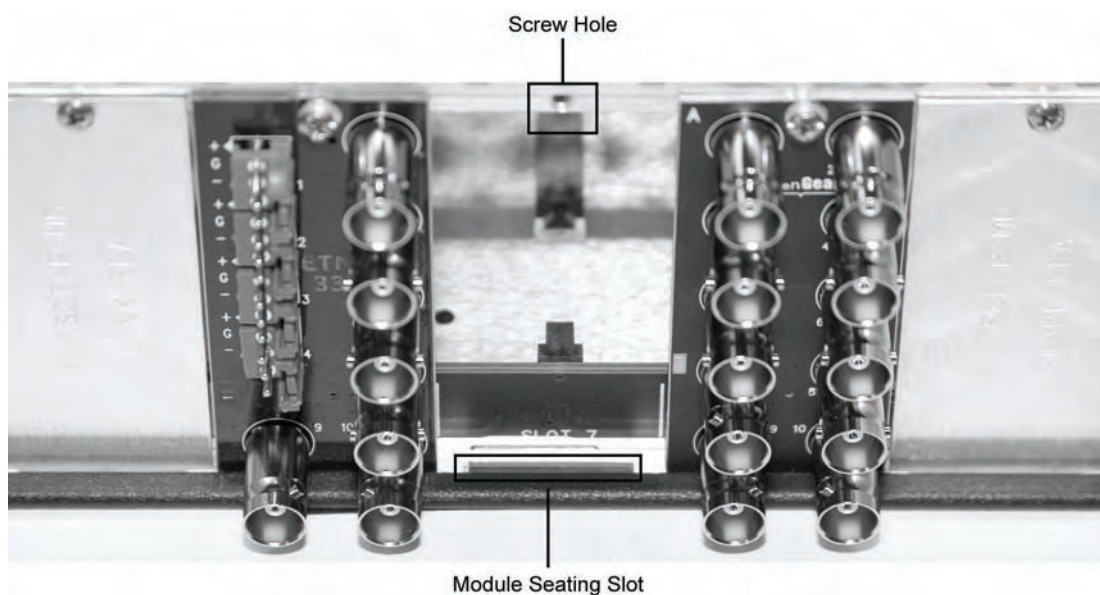

Figure 2.4 Rear Module Installation — DFR-8310 series frame

6. Align the top screw of the Rear Module with the screw hole on the top edge of the DFR-8300 series frame back plane. (**Figure 2.4**)
7. Ensure the module aligns with the desired card slot before tightening the screws.



Note — Verify that the card aligns with the Rear Modules before tightening the slot screws.

8. Using a Phillips screwdriver and the supplied screw, fasten the Rear Module panel to the DFR-8300 series frame back plane. Do not over tighten.
9. Install the rear module label (supplied with each card).
10. Ensure proper frame cooling and ventilation by having all rear frame slots covered with Rear Modules or blank metal plates.

This completes the procedure for installing a Rear Module Rear Module in a DFR-8300 series frame.

For More Information...

- on installing your DFR-8300 series frame, refer to the section “**Installing a DFR-8300 Series Frame**” on page 2-3.
- on the rear module cabling required by your openGear card, refer to the card *User Manual*.

Network Connections

To monitor and control openGear cards via DashBoard Control System, you must have a Network Controller card installed and configured in your DFR-8300 series frame. Consult your IT Department before configuring any network settings.

For More Information...

- on installing and configuring your Network Controller card, refer to the ***MFC-8300 Series User Manual***
- on installing and using DashBoard, refer to the ***DashBoard Control System User Manual***.

DFR-8310 Series Setup

In This Chapter

This chapter provides information on using the DFR-8310 series frames. The DFR-8310 is a 2RU modular frame, designed to accommodate up to 10 cards of our openGear Multi-Definition product family.

The following topics are discussed:

- Rear Modules for the DFR-8310 Series Frames
- SMPTE Fault Reporting Option
- Cooling Features
- Specifications for the DFR-8310 Series Frames



Note — *The power dissipation of each product installed in this frame is indicated in the section “**Specifications**” of the documentation provided with each module. For long-term reliability and increased product life, it is recommended that the total dissipation of all modules installed in a DFR-8310 series frame should not exceed 40W total without the CFM-8310, and 120W total with the CFM-8310. In addition, frames without the CFM-8310 should be provided with one rack unit of empty space above and below each frame for ventilation.*

*Refer to the section “**Ventilation and Cooling**” on page 2-11 for further information and options for higher load applications requiring greater heat dissipation.*

Rear Modules for the DFR-8310 Series Frames

Depending on the frame model you purchased, there may be variations in the Rear Modules connected to it. If the frame was ordered with cards requiring a Rear Module, the appropriate modules will be installed at the factory or included with the card modules. You must have a **Blank Rear Module (R1-BLANK)** installed when the slot does not have an openGear card installed. This helps to ensure proper frame cooling and ventilation.

- **DFR-8310** and **DFR-8310-C** frames come without pre-installed rear modules.
- **DFR-8310-BNC** and **DFR-8310-C-BNC** frames come with pre-installed with ten 10-BNC Rear Modules.

Consult the installation section of each card's manual for Rear Module cabling designations. Each card also comes with the required Rear Module Label to place on the Rear Module.



Rear Module with
6 BNCs and
4 AES Connectors



Standard Rear Module
with 10 BNCs

Figure 3.1 Examples of DFR-8310 Rear Modules

For More Information...

- on the Rear Module required, refer to the *User Manual* for your specific openGear card.
- on installing Rear Modules, refer to the section “**Rear Module Installation**” on page 2-12.

SMPTE Fault Reporting Option

The SMPTE 269M Fault Reporting system, also known as a SMPTE “alarm”, provides an indication if one or more frame cards encounter a fault or an abnormal condition. This option is available when an MFC-8310 or MFC-8310-N is installed in the Frame Controller Slot of a DFR-8310 frame. The MFC-8310 is included if the frame has cooling fans in the front door. The individual card(s) can report fault conditions to the MFC-8310(-N) frame controller card, which in turn drives a BNC connector on the DFR-8310 series frame. When the frame connection is interfaced with a customer-designed system of LEDs or audible alarms, faults can be traced to a specific frame when a card fault occurs within that frame. For additional information on alarm system design, refer to the SMPTE document *ANSI/SMPTE 269M - 1999*.

Frame Connections

The SMPTE 269M Fault Reporting connection on openGear DFR-8310 series frames is provided by the FAULT BNC connector, for interfacing with a customer-designed alarm system. Refer to **Figure 3.2** for the connector location.

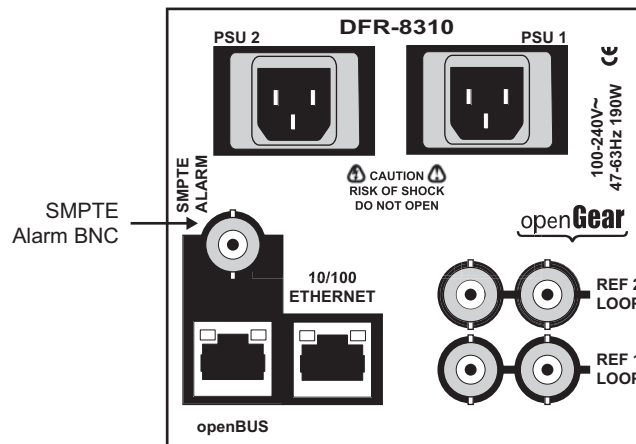

Figure 3.2 SMPTE 269M Alarm Reporting Frame Connections

The SMPTE Alarm BNC connector may be wired to an external alarm system for reporting alarms in SMPTE 269M format. The circuit can drive a 20mA alarm load. For more details on this type of system, refer to the document *ANSI/SMPTE 269M - 1999*, available from SMPTE.

Details

The fault report contacts are closed when the card detects an internal failure or a power loss condition. The fault report contacts are closed for about 2 milliseconds every 16 ms to report any error for which SMPTE fault reporting has been enabled.

Some internal failures may include:

- Hardware failure of any card or power supply.
- Loss of AC power to any power supply
- “Soft” errors from any card setup to detect and report such errors

Cooling Features

The standard DFR-8310 frame can be also ordered as the DFR-8310-C version, with the Cooling Fan Module installed as original equipment from the factory. However, for customers wishing to increase the ventilation on their standard DFR-8310 frames, the optional CFM-8310 Cooling Fan Module is available as a field upgrade kit.

The CFM-8310 module consists of a fan board, which installs in the frame door, and a controller card, which installs in a designated frame slot. The controller may be either an MFC-8310, which provides fan control and local alarm monitoring, or an MFC-8310-N, which provides fan control, alarm monitoring, and support for remote monitoring and control via Ethernet. Installation instructions are provided in this chapter for both types of controller cards.

Installing the Cooling Fan Module

This section includes instructions on installing the Fan Board component of the CFM-8310 module and an outline of the Functions and User Controls of the module. After you install the CFM-8310 module, you must install the MFC-8310 or the MFC-8310-N controller card.

Installing the Cooling Fan Module

Refer to **Figure 3.3** when installing the Fan Board component of the CFM-8310:

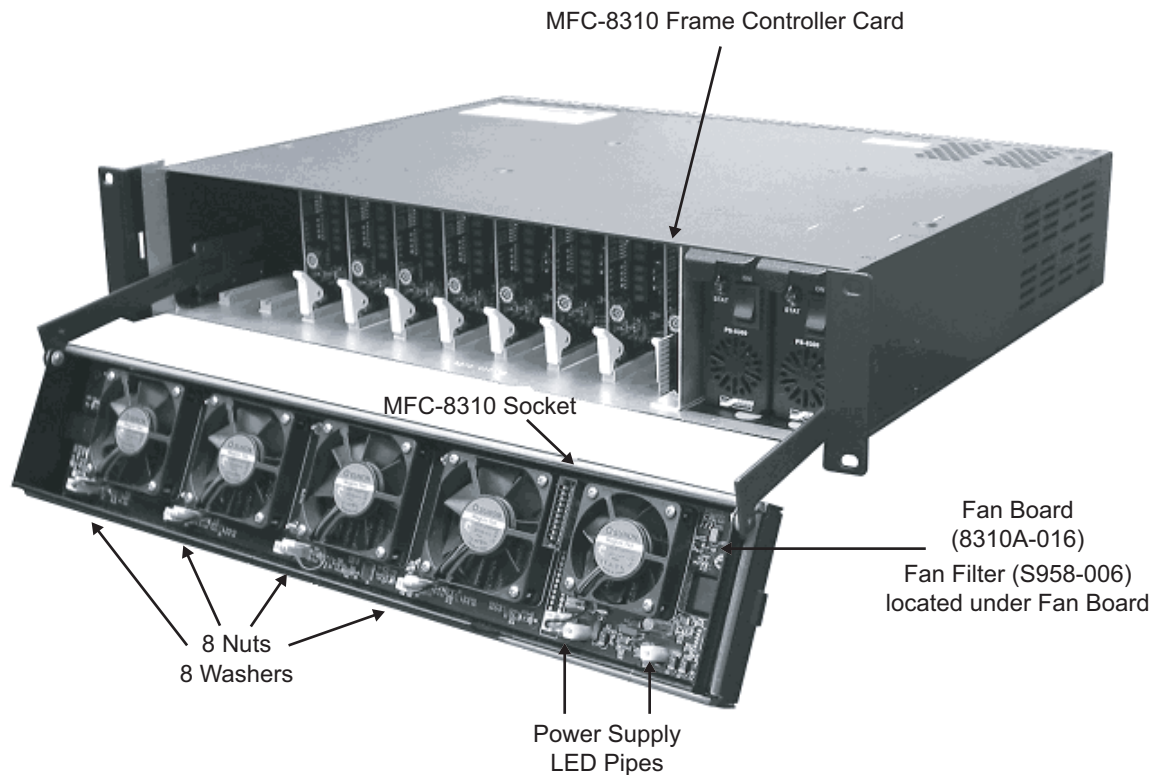

Figure 3.3 CFM-8310 Cooling Fan Module

Use the following procedure to install the Fan Board component of the CFM-8310:

1. Open the CFM-8310 package and remove the components. Verify that all necessary components are included.
 - Fan PCB 8310A-016
 - Fan Filter S985-006
 - 8 nuts 650-007
 - 8 washers 960-025
 - MFC-8310(-N) Controller Card
2. Turn frame power off.
3. Open the frame door.
4. Carefully remove the door from the frame by unscrewing the two screws that attach the door to the extender arms.
5. Place the frame door inside up on a clean antistatic workspace.
6. Install the Fan Filter as follows:
 - Insert the Fan Filter with the panhandle over the smaller fan vents and the cut corner adjacent to the LED pipes already on the door.
 - Gently push the filter down so the mounting bolts pass through cleanly.
7. Place a washer on each of the 8 mounting bolts.
8. Align the Fan PCB with the fans up so the LED pipes pass through their board holes.
9. Ensure the **Alarm Mute** button clears its door hole and that the **Fault** and **Fan Fail** LEDs clear their door holes while you slowly press the Fan PCB (8310A-016) down onto the 8 mounting bolts. Refer to **Figure 3.3** for details on these item locations.
10. On the frame door, check that the **Alarm Mute** button pushes in and out without binding.
11. Tighten the 8 nuts until they just make contact with the rubber grommets on the Fan PCB. Do not over tighten.
12. Reconnect the door to the frame extender arms with the two screws from step 4.

This completes the procedure to install the Fan Board component of the CFM-8310 module. Next you will learn about the CFM-8310 functions and user controls.

Cooling Fan Functions and User Controls

The CFM-8310 provides LED and Alarm switching controls to the front edge of the DFR-8310 frame door. For details on the installing and using the MFC-8310-N controller card, refer to the *MFC-8300 Series User Manual*.



Figure 3.4 DFR-8310 Series Frame Door Features

Specifications for the DFR-8310 Series Frames

This section includes the technical specifications for the DFR-8310 series frames.

Table 3.1 DFR-8310 Series Technical Specifications

Category	Parameter	Specification
PS-8300 Power Supply	Input	100 - 240VAC, 47-63Hz, 190W
	Output 1	+12V, $\pm 10\%$, 0.5A - 12.5A
	Output 2	-7.5V, $\pm 10\%$, 0A - 2.5A
	Total	Sum of both outputs not to exceed 150W maximum
Rack Frame Mechanical	Height	3.5" (8.89cm)
	Width	19" (48.26cm)
	Depth	15.625" (39.69cm)
	Weight, with a PS-8300 installed	10lbs (4.5kg)
Frame Card Slots	Number of Slots	10
	Max Power: +12V Rail	1.0A (12W)
	Max Power: -7.5V Rail	0.2A (1.5W)
	Total	120W, total power consumption not to exceed 12W maximum per card slot
Frame Controller and Fans	Max Power: +12V Rail	1.5A (18W)
	Max Power: -7.5V Rail	0.2A (1.5W)
	Total	19.5W maximum
openBus Remote Power	Max Power: +12V Rail	2.0A (24W), total frame power not to exceed 150W total
Reference Inputs	Number of Inputs	2 looping
	Level	1Vpp nominal
	Signal	Analog video sync (black burst or tri-level), or AES/EBU DARS
	Impedance	75ohm terminating
	Return Loss	>30dB to 30MHz
	Max DC on Ref Input	$\pm 1V$
SMPTE Fault Reporting	Alarm Indicator	ANSI/SMPTE 269M-1999 contact closure
	Connector	Female BNC
	Max Voltage	24V DC

Table 3.1 DFR-8310 Series Technical Specifications

Category	Parameter	Specification
SMPTE Fault Reporting	Max Current	20mA
	Alarm Conditions	Loss of AC input power
		DC output voltage error
	PS Monitored Parameters (-C version only)	DC output voltage
		DC output current
		Critical temperature
		PS-8300 fan failure
	Frame Monitored Parameters (-C version only)	Backplane rail voltage
		Cooling fan failure
		Ambient temperature
	Alarm Indicators (-C version only)	System fault LED
		Fan failure LED
		Frame controller audio alarm
		Frame door audio alarm
Environmental	Ambient temperature range	0 °C to 40 °C
	Humidity, non condensing	<95%

Specifications are subject to change without notice.

DFR-8321 Series Setup

In This Chapter

This chapter provides information on setting up and using the DFR-8321 series frame. The DFR-8321 is a 2RU modular frame, designed to accommodate up to 20 openGear cards and support up to 10 high-density openGear fiber cards.

The following topics are discussed:

- Rear Modules for the DFR-8321 Series Frames
- Cooling Features
- Specifications for the DFR-8321 Series Frames

Rear Modules for the DFR-8321 Series Frames

If your DFR-8321 series frame was ordered with cards requiring Full Rear Modules or Split Rear Modules, the appropriate modules are installed at the factory or included with the cards. **Blank Rear Modules (R2-BLANK)** are installed when the slot does not have an openGear card installed. This helps to ensure proper frame cooling and ventilation.

Full Rear Module

The Full Rear Module features a single card connector and can include up to 10 BNCs, or a combination of BNC, AES, and fiber optic connectors. Each module occupies two slots in the frame and the openGear card must be installed in an even slot number, such as slot 2 or 4. Up to 10 cards can be installed using this rear module type. (**Figure 4.1**)

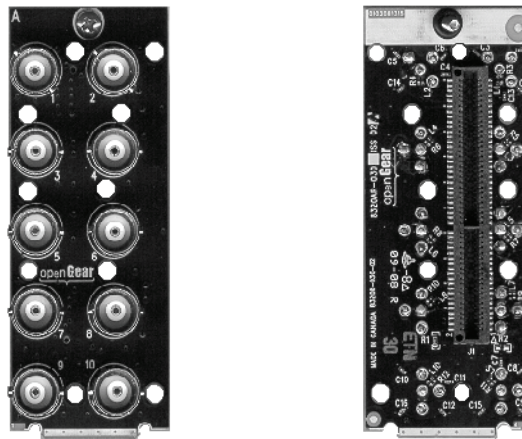

Figure 4.1 Full Rear Module — Ten BNC Connectors

Split Rear Module

This module features two card connectors and can include up to 10 BNCs, or a combination of BNC, AES, and fiber optic connectors. Each card connector is routed to a column of five BNCs. This module can only be used in a DFR-8321 series frame. A Split Rear Module occupies two slots in the frame but provides connectors for two openGear cards. Up to 20 cards can be installed in the frame using this type of rear module. (**Figure 4.2**)

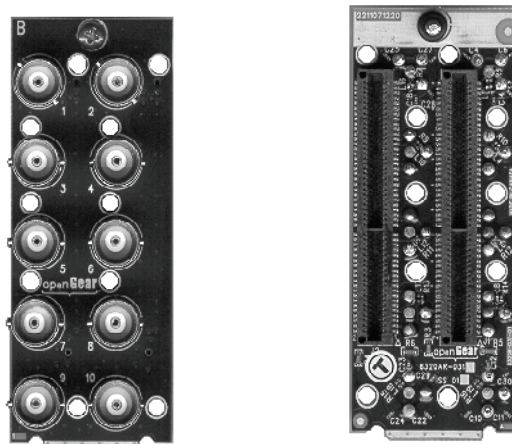

Figure 4.2 Split Rear Module — Ten BNC Connectors

Cooling Features

The DFR-8321 series frames come standard with the Cooling Fan Module installed as original equipment from the factory. However, if you need to replace the ventilation in a DFR-8321 series frame door, the optional CFM-8321 Cooling Fan Module is available as a field installation kit.

Cooling Fan Functions and User Controls

The DFR-8321 series frames includes Fault LEDs and the Alarm mute button on the front of the frame door. For details on the LED functions, refer to **Table 2.2**. For operational details for your MFC-8300 series controller card, refer to the *MFC-8300 Series User Manual*.



Figure 4.3 DFR-8321 Series Frame Door Features

Replacing the CFM-8321 Cooling Fan Module

This section includes instructions on installing the CFM-8321 Cooling Fan Module Replacement Kit. The CFM-8321 Cooling Fan Module Replacement Kit includes the fan board and filter pre-installed in a new DFR-8321 series frame door.

Use the following procedure to replace the CFM-8321 Cooling Fan Module:

1. Carefully remove the door from the frame as follows:
 - Gently pull the side door tabs towards the center of the door, releasing the door from the frame. The door extender arms prevent the door from falling.
 - Using both hands, pull the door towards you.
 - Tilt the door upward until the arms match the cutout.
 - Gently push the door extender arms in and over the retaining bolts and unhook from the frame.
 - Remove the door and place it on a clean, flat, static-free surface.
2. On the new frame door of the CFM-8321 Cooling Fan Module, verify that the **Alarm Mute** button pushes in and out without binding.
3. Install the CFM-8321 Cooling Fan Module in the frame as follows:
 - Using both hands, with the door tilted up, slide the new door into the frame while pushing the extender arms in and over the retaining bolts.
 - Pull and release the door tabs to ensure the frame door is securely locked to the DFR-8321 series frame.

This completes the procedure for replacing the CFM-8321 Cooling Fan Module.

Specifications for the DFR-8321 Series Frames

This section includes the Technical Specifications table for the DFR-8321 series frame.

Table 4.1 DFR-8321 Series Frame Technical Specifications

Category	Parameter	Specification
PS-8300 Power Supply	Input	100-240VAC, 47-63Hz, 190W
	Output 1	+12V, $\pm 10\%$, 0.5A - 12.5A
	Output 2	-7.5V, $\pm 10\%$, 0A - 1.5A
	Total	Sum of both outputs not to exceed 150W maximum
Rack Frame Mechanical	Height	2RU 3.5" (8.89cm)
	Width	19" (48.26cm)
	Depth	17" (43.18cm)
	Weight, with 1 PS-8300 installed	13lbs (5.90kg)
Frame Card Slots	Number of Slots	20
	Max Power: +12V Rail	2.0A (24W)
	Max Power: -7.5V Rail	0.2A (1.5W)
	Total	120W, total power consumption not to exceed 24W maximum per card slot
Frame Controller and Fans	Max Power: +12V Rail	1.5A (18W)
	Max Power: -7.5V Rail	0.2A (1.5W)
	Total	19.5W maximum
Comm I/O Controller	Max Power: +12V Rail	0.2A (2.4W)
	Max Power: -7.5V Rail	0.2A (1.5W)
	Total	3.9W maximum
Reference Inputs	Number of Inputs	2 looping
	Level	1Vpp nominal
	Signal	Analog video sync (black burst or tri-level), or AES/EBU DARS
	Impedance	75ohm terminating
	Return Loss	>30dB to 30MHz
	Max DC on Ref Input	$\pm 1V$
Environmental	Ambient temperature range	0 °C to 40 °C
	Humidity, non condensing	<95%

Specifications are subject to change without notice.

Service Information

In This Chapter

This chapter contains the following sections:

- Troubleshooting Checklist
- Warranty and Repair Policy

Troubleshooting Checklist

Routine maintenance to this openGear product is not required. In the event of problems with your DFR-8300 series frame, the following basic troubleshooting checklist may help identify the source of the problem. If the frame still does not appear to be working properly after checking all possible causes, please contact your openGear products distributor, or the Technical Support department at the numbers listed in the section “**Contact Us**”.

- 1. Visual Review** — Performing a quick visual check may reveal many problems, such as connectors not properly seated or loose cables. Check the card, the frame, and any associated peripheral equipment for signs of trouble.
- 2. Power Check** — Check the power indicator LED on the distribution frame front panel for the presence of power. If the power LED is not illuminated, verify that the power cable is connected to a power source and that power is available at the power main. Confirm that the power supplies are fully seated in their slots. If the power LED is still not illuminated, replace the power supply with one that is verified to work.
- 3. Input Signal Status** — Verify that source equipment is operating correctly and that a valid signal is being supplied.
- 4. Output Signal Path** — Verify that destination equipment is operating correctly and receiving a valid signal.
- 5. Unit Exchange** — Exchanging a suspect unit with a unit that is known to be working correctly is an efficient method for localizing problems to individual units.

Warranty and Repair Policy

The DFR-8300 series frame is warranted to be free of any defect with respect to performance, quality, reliability, and workmanship for a period of FIVE (5) years from the date of shipment from our factory. In the event that your DFR-8300 series frame proves to be defective in any way during this warranty period, Ross Video Limited reserves the right to repair or replace this piece of equipment with a unit of equal or superior performance characteristics.

Should you find that this DFR-8300 series frame has failed after your warranty period has expired, we will repair your defective product should suitable replacement components be available. You, the owner, will bear any labor and/or part costs incurred in the repair or refurbishment of said equipment beyond the FIVE (5) year warranty period.

In no event shall Ross Video Limited be liable for direct, indirect, special, incidental, or consequential damages (including loss of profits) incurred by the use of this product. Implied warranties are expressly limited to the duration of this warranty.

This DFR-8300 series frame User Manual provides all pertinent information for the safe installation and operation of your openGear Product. Ross Video policy dictates that all repairs to the DFR-8300 series frame are to be conducted only by an authorized Ross Video Limited factory representative. Therefore, any unauthorized attempt to repair this product, by anyone other than an authorized Ross Video Limited factory representative, will automatically void the warranty. Please contact Ross Video Technical Support for more information.

In Case of Problems

Should any problem arise with your DFR-8300 series frame, please contact the Ross Video Technical Support Department. (Contact information is supplied at the end of this publication.)

A Return Material Authorization number (RMA) will be issued to you, as well as specific shipping instructions, should you wish our factory to repair your DFR-8300 series frame. If required, a temporary replacement frame will be made available at a nominal charge. Any shipping costs incurred will be the responsibility of you, the customer. All products shipped to you from Ross Video Limited will be shipped collect.

The Ross Video Technical Support Department will continue to provide advice on any product manufactured by Ross Video Limited, beyond the warranty period without charge, for the life of the equipment.

Notes:



Contact Us

Contact our friendly and professional support representatives for the following:

- Name and address of your local dealer
- Product information and pricing
- Technical support
- Upcoming trade show information

PHONE	General Business Office and Technical Support	613 • 652 • 4886
	After Hours Emergency	613 • 349 • 0006
	Fax	613 • 652 • 4425
E-MAIL	General Information	solutions@rossvideo.com
	Technical Support	techsupport@rossvideo.com
POSTAL SERVICE	Ross Video Limited	8 John Street, Iroquois, Ontario, Canada K0E 1K0
	Ross Video Incorporated	P.O. Box 880, Ogdensburg, New York, USA 13669-0880

Visit Us

Please visit us at our website for:

- Company information
- Related products and full product lines
- On-line catalog
- News
- Testimonials

www.rossvideo.com
